

A1

Index

DESCRIPTION	FRAME NO.
<u>LOWER SALOON</u> SHELL FLOOR COVERING BOTTOM FRAME	A2 to A11 (8901 P) B1 to B8 (8901 B2) C1 to D10 (8901 A)

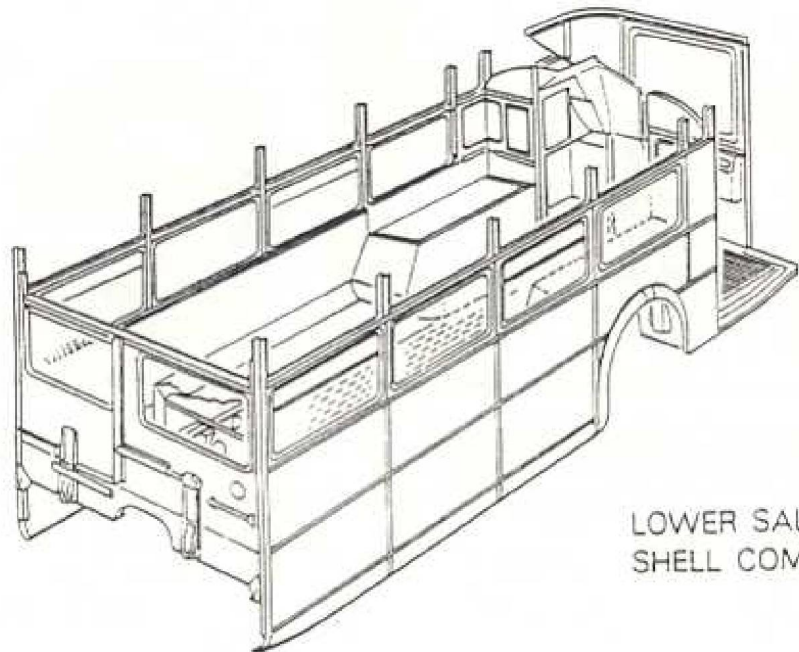

LOWER SALOON
SHELL COMPLETE

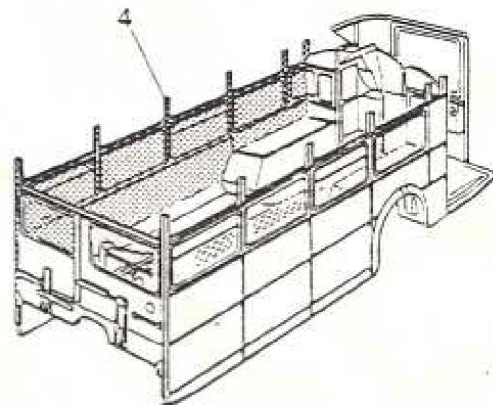
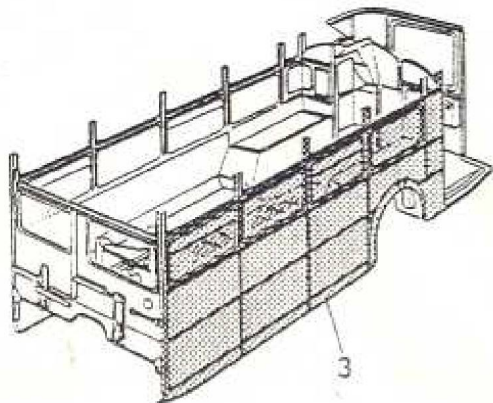
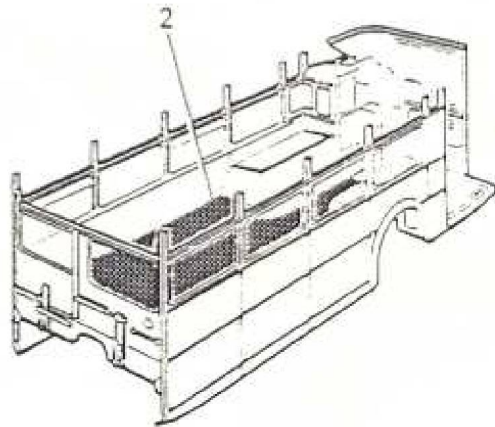
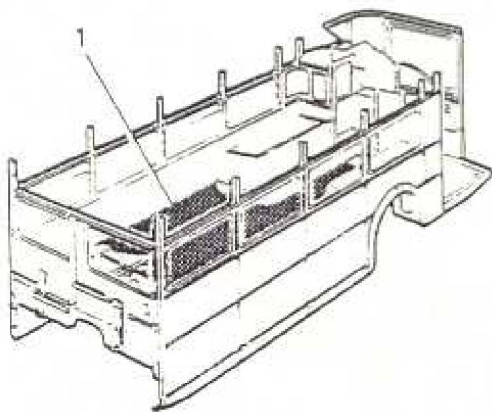

ITEM	MAN. REF.	PART NUMBER	A/D	ASSEMBLY - A	DETAIL - D	QTY.	REMARKS	ISSUE
				DESCRIPTION				
		RM 001 PL1	A	Lower Saloon Shell		1		
1		RM 012 BL	A	Floor Coverings		1	Ref B901 BL (E2)	
2		RM 001 A1	A	Bottom Frame		1	Ref B901 A (C2)	
3		RM 001 CL	A	L/S, Side Frame N/S		1	Ref B901 CL (A7)	
4		RM 002 CL1	A	L/S, Side Frame O/S		1	Ref B901 CL (B10)	

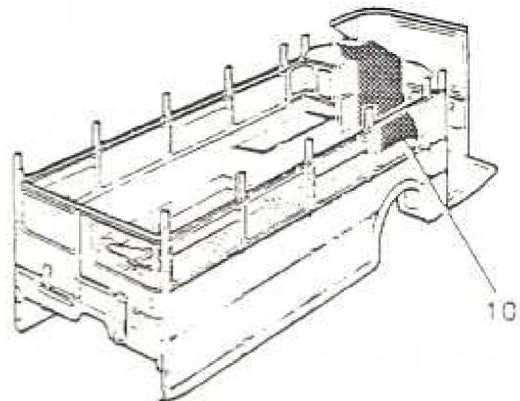
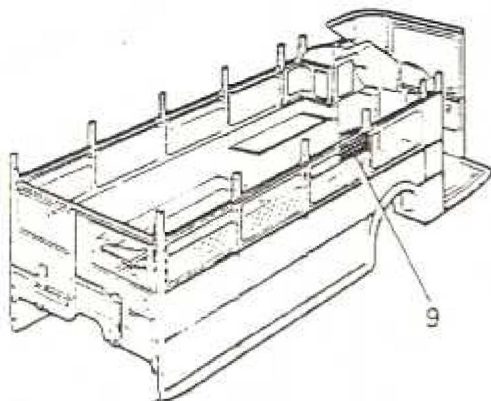
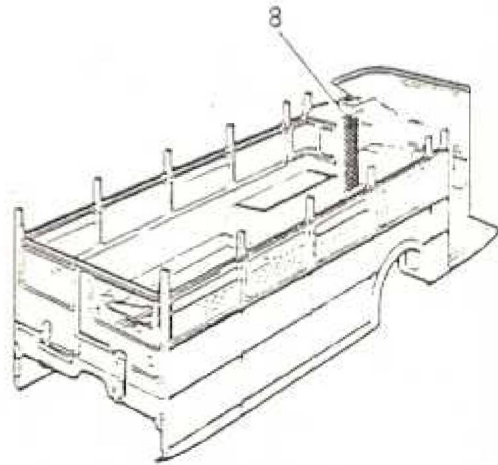
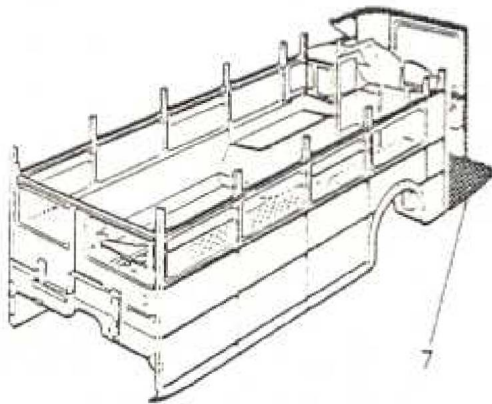
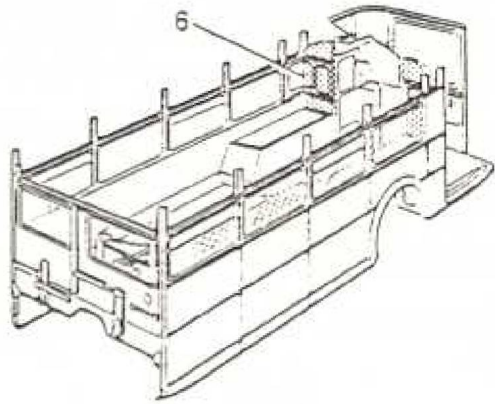
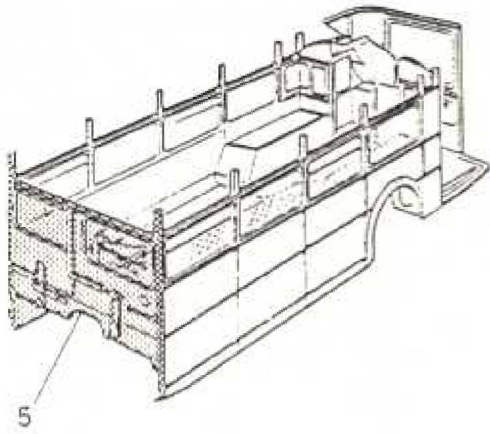

ITEM	MAN. REF.	PART NUMBER	ASSEMBLY - A		QTY.	REMARKS	ISSUE
			A/D	DETAIL - D			
			DESCRIPTION				
5		RM 001 E	A	Front Bulkhead	1	Ref B901 EL (D9)	
6		RM 001 F	A	Rear Bulkhead	1	Ref B901 FL (A9)	
7		RM 001 FL	A	Rear End	1	Ref B901 FL (B6)	
8		RM 007 K1	A	Conductors Locker	1	Ref B901 K (A3)	
9		RM 008 K	A	Battery Compartment	1	Ref B901 K (A7)	
10		RM 001 K	A	Staircase	1	Ref B901 K (B3)	
<u>ATTACHING PARTS</u>							
*		RM 012 PL	A	Front Bulkhead to Bottom Frame	1		
*		RM 013 PL	A	Rear Bulkhead to Bottom Frame and Platform	3		
*		RM 014 PL	A	Front Bulkhead to Sideframe	1		
*		RM 015 PL	A	Front Bulkhead to Sideframe	1		
*		RM 016 PL	A	Rear Bulkhead to Sideframe	1		
*		RM 017 PL	A	Rear Bulkhead to Sideframe and Rear Frame	1		
*		RM 018 PL	A	Sideframe to No. 2 and 3 Cross Bar	4		
*		RM 019 PL	A	Sideframe to No. 4 Cross Bar	2		
*		RM 020 PL	A	Bottom Frame Flooring and Wheel Arch to Side Frame	1		

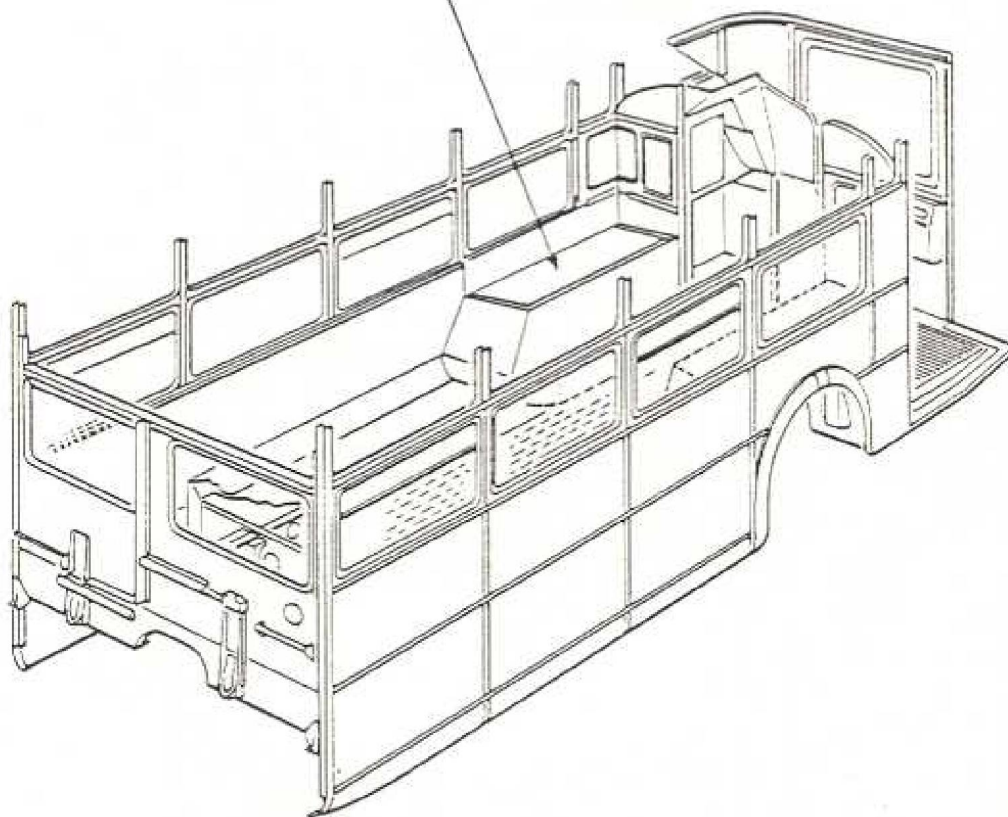
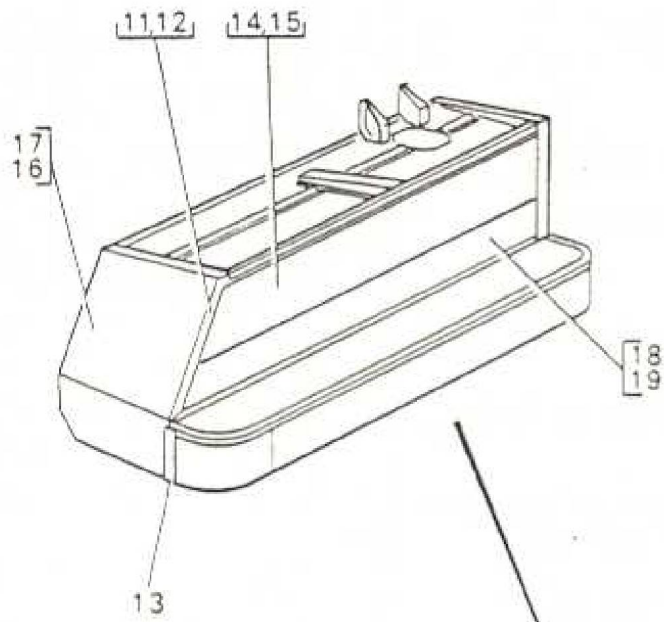

ITEM	MAN. REF.	PART NUMBER	ASSEMBLY - A		DETAIL - D		QTY.	REMARKS	ISSU
			A/D	DESCRIPTION					
11		RM 001 PL22	D	Finisher Angle Long'l Seat N/S			1		
12		RM 001 PL23	D	Finisher Angle Long'l Seat O/S			1		
13		RM 001 PL24	D	Footstool Finisher Cover Strap			2		
14		RM 001 PL32	D	Seat Riser Cover N/S			1		
15		RM 001 PL33	D	Seat Riser Cover O/S			1		
16		RM 008 PL1	A	Front Finisher Panel N/S Long'l Seat			1		
17		RM 009 PL1	A	Front Finisher Panel O/S Long'l Seat			1		
18		RM 001 PL34	D	Kicking Panel Seat Riser N/S			1		
19		RM 001 PL35	D	Kicking Panel Seat Riser O/S			1		
*		RM 001 PL44	D	Cable Cover - Coving			1		

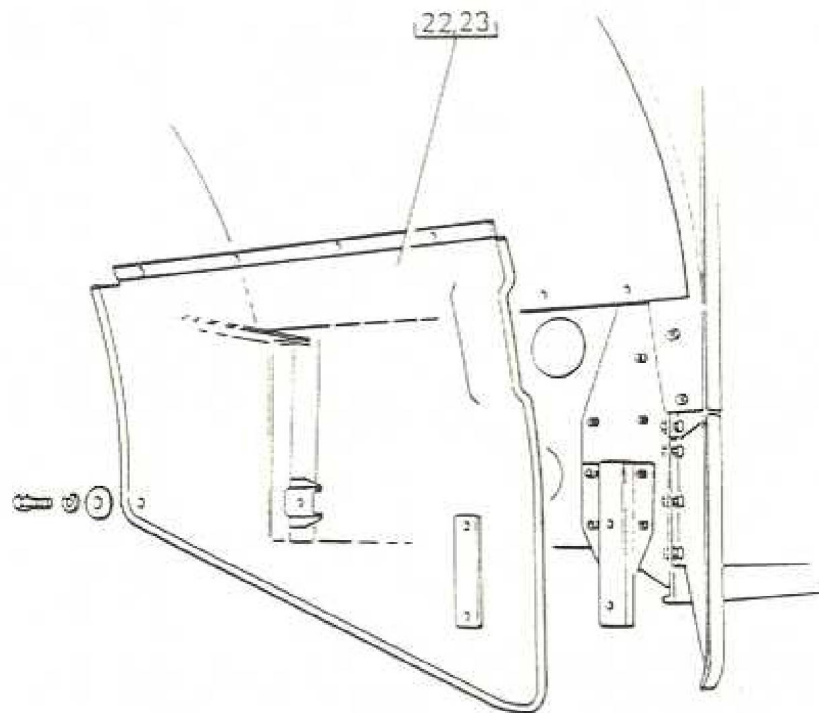
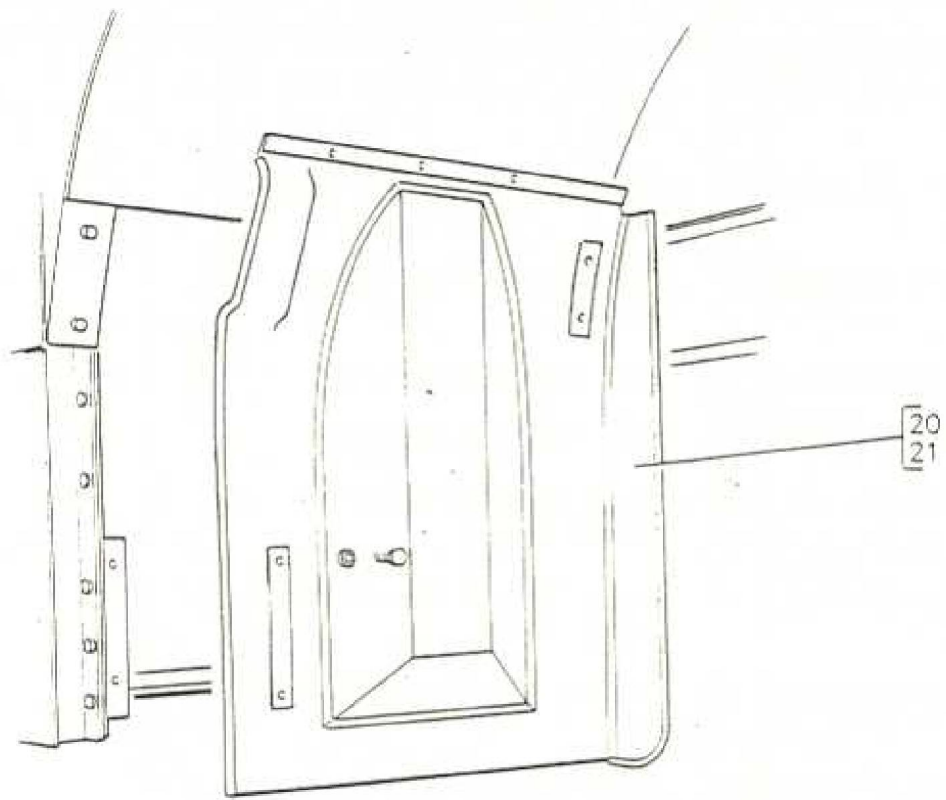

ITEM	MAN. REF.	PART NUMBER	A/D	ASSEMBLY * A	DETAIL * D	QTY.	REMARKS	ISSUE
				DESCRIPTION				
20		RM 088 N1	A	Rear Wheel Arch Panel Rear Section N/S		1	Before MOD 261	
21		RM 089 N1	A	Rear Wheel Arch Panel Rear Section O/S		1	After MOD 21	
22		RM 081 N1	A	Rear Wheel Arch Panel Front Section N/S		1		
23		RM 082 N1	A	Rear Wheel Arch Panel Front Section O/S		1		

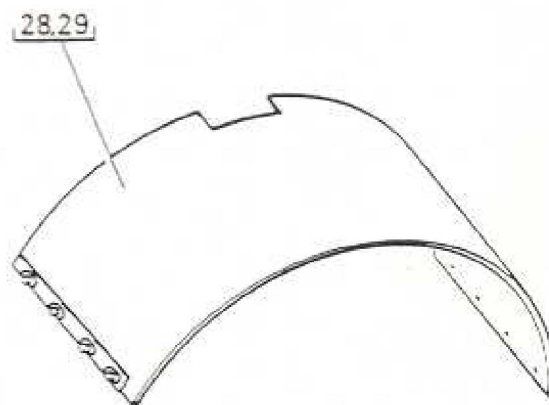
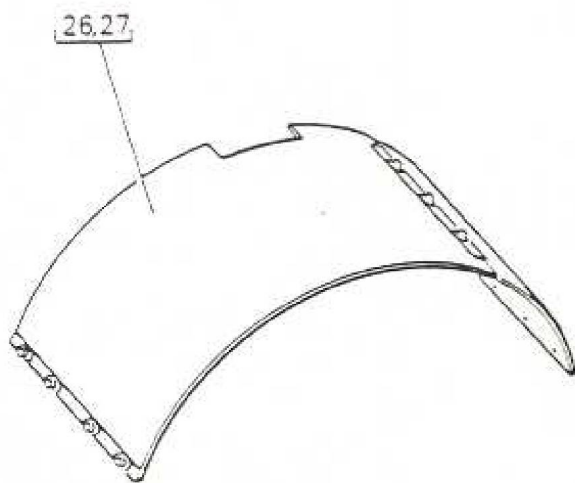
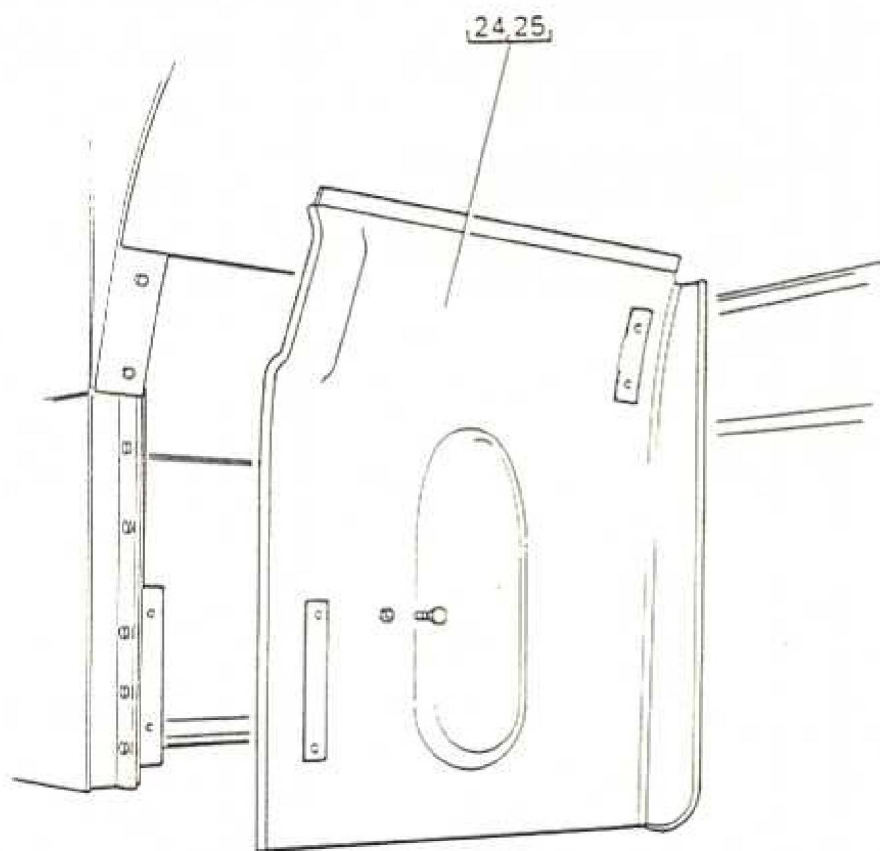

ITEM	MAN. REF.	PART NUMBER	A/D	ASSEMBLY * A	DETAIL * D	QTY.	REMARKS	ISSUE
				DESCRIPTION				
24		RM 079 N1	A	Rear Wheel Arch Panel Rear Section N/S			After MOD 261	
25		RM 080 N1	A	Rear Wheel Arch Panel Rear Section O/S			Before MOD 21	
26		RM 092 N1	A	Rear Wheel Arch Panel Top Section N/S		1	Before MOD 261	
27		RM 093 N1	A	Rear Wheel Arch Panel Top Section O/S		1	After MOD 21	
28		RM 083 N1	A	Rear Wheel Arch Panel Top Section N/S		1	After MOD 261	
29		RM 084 N1	A	Rear Wheel Arch Panel Top Section O/S		1	Before MOD 21	

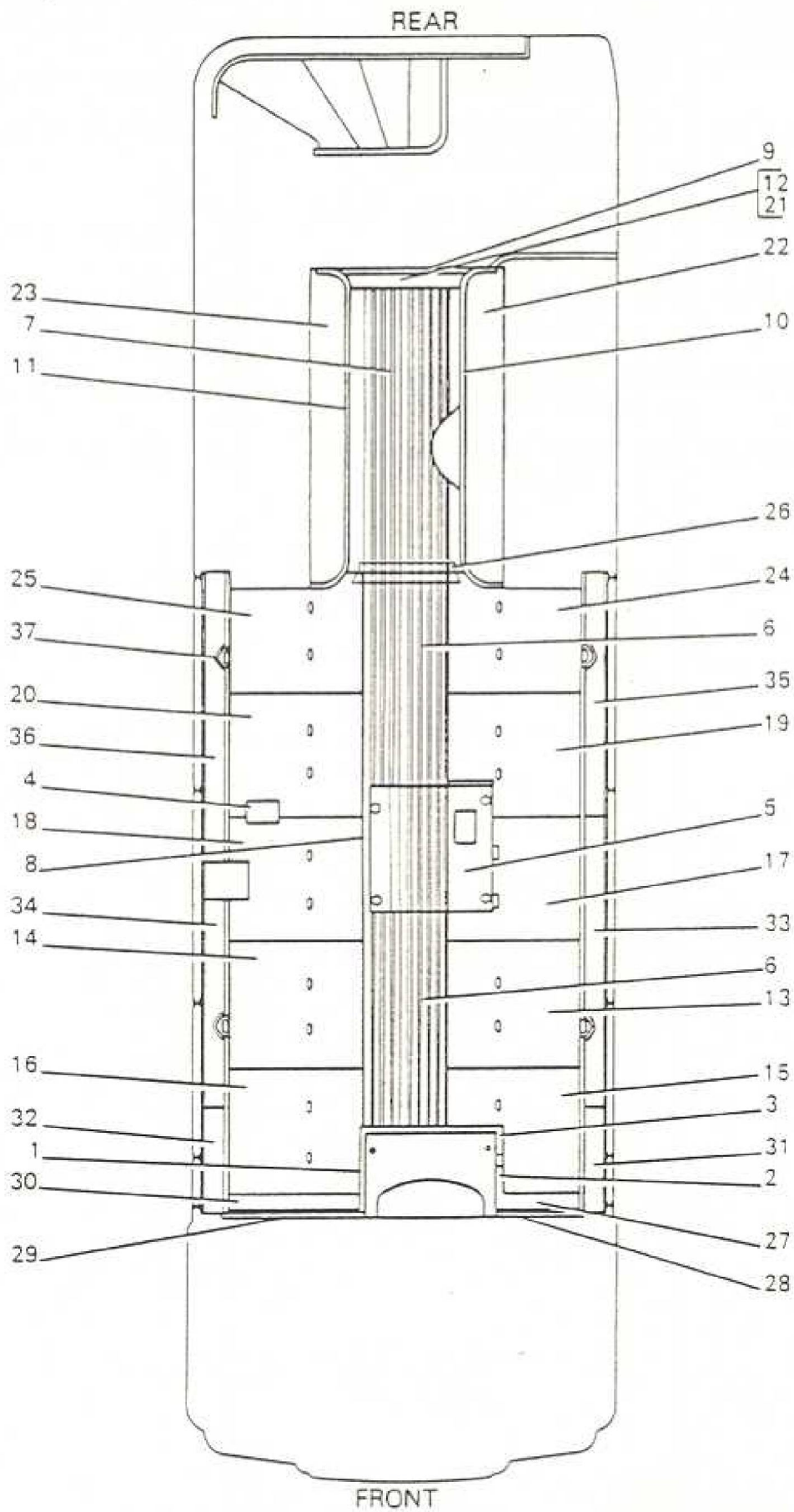

ITEM	MAN. REF.	PART NUMBER	ASSEMBLY - A		DETAIL - D		QTY.	REMARKS	ISSUE
			A/D	DESCRIPTION					
		RM 012 BL	A	Floor Covering			1	Before MOD 434	
		RM 027 BL	A	Floor Covering - Multislat			1	After MOD 434	
1		RM 028 BL1/P	A	Treadplate O/S Flywheel			1		
2		RM 029 BL1/P	A	Treadplate N/S Front Flywheel			1		
3		RM 030 BL1/P -	A	Treadplate N/S Rear Flywheel			1		
4		RM 007 BL1	A	Inspection Trap			1		
5		RM 031 BL1	A	Gearbox Trap (Multislat)			1		
*		RM 004 BL1	A	Dipstick & Filler Trap			1		
*		RM 005 BL1/P	A	Trap Fastening N/S			2		
*		RM 006 BL1/P	A	Trap Fastening O/S			2		
*		RM 075 A1	A	Gearbox Trap without Slatting			1		
*		RM 027 BL11	D	Gangway Tile N/S No. 4 Bay			1	RM 7 only after ADV BA 480	
*		RM 027 BL12	D	Gangway Multislat No. 4 Bay			1	Before ADV BA 491	
*		RM 027 BC13	D	Gangway Tile O/S No. 4 Bay			1		
*		RM 027 BL2/P	D	Treadplate Flywheel Cowl			2		
*		RM 027 BL3	D	Treadplate Packing			1		
6		RM 027 BL4	D	Gangway Multislat			2		
7		RM 027 BL5	D	Gangway Multislat Rear			1		
8		RM 027 BL8	D	Single Slat at Gearbox O/S			1		

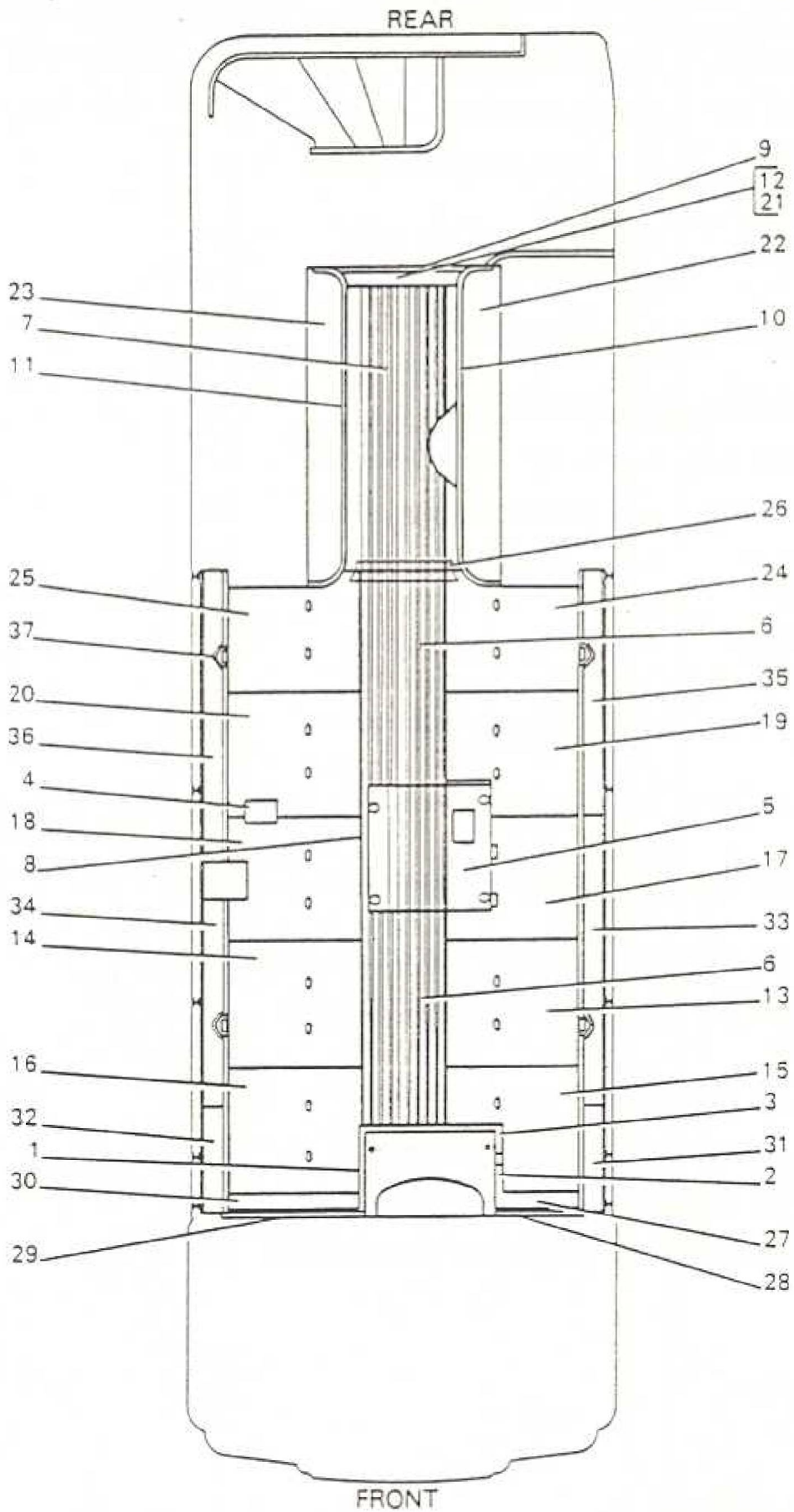

ITEM	MAN. REF.	PART NUMBER	A/D	ASSEMBLY * A	DETAIL * D	QTY.	REMARKS	ISSUE
				DESCRIPTION				
*		RM 027 BL10	D	Gangway Multislat		1	RM 7 only	
*		RM 001 BL36T	D	Bulkhead Edge Slat N/S		1		
*		RM 001 BL37T	D	Bulkhead Edge Slat O/S		1		
9		RM 001 BL/38F	D	Entrance Nosing		1	Before A/A BZ 1079	
10		RM 001 BL39/F	D	Footstool Nosing N/S		1		
11		RM 001 BL40/F	D	Footstool Nosing O/S		1		
12		RM 012 BL8	D	Entrance Slat		1		
13		RM 012 BL10	D	Floor Tile No. 2 N/S		1		
14		RM 012 BL11	D	Floor Tile No. 2 O/S		1		
*		RM 012 BL12	D	Floor Tile No. 3A Pillar N/S		1	RM 7 only	
*		RM 012 BL13	D	Floor Tile No. 3A Pillar O/S		1		
15		RM 012 BL45	D	Floor Tile No. 1 N/S		1		
16		RM 012 BL46	D	Floor Tile No. 1 O/S		1		
17		RM 012 BL47	D	Floor Tile No. 3 N/S		1		
18		RM 012 BL48	D	Floor Tile No. 3 O/S		1		
19		RM 012 BL49	D	Floor Tile No. 4 N/S		1		
20		RM 012 BL50	D	Floor Tile No. 4 O/S		1		
21		RM 001 BL45	D	Entrance Nosing		1	After A/A BZ 1079	
22		RM 012 BL57	D	Floor Tile Footstool N/S		1		
23		RM 012 BL58	D	Floor Tile Footstool O/S		1		

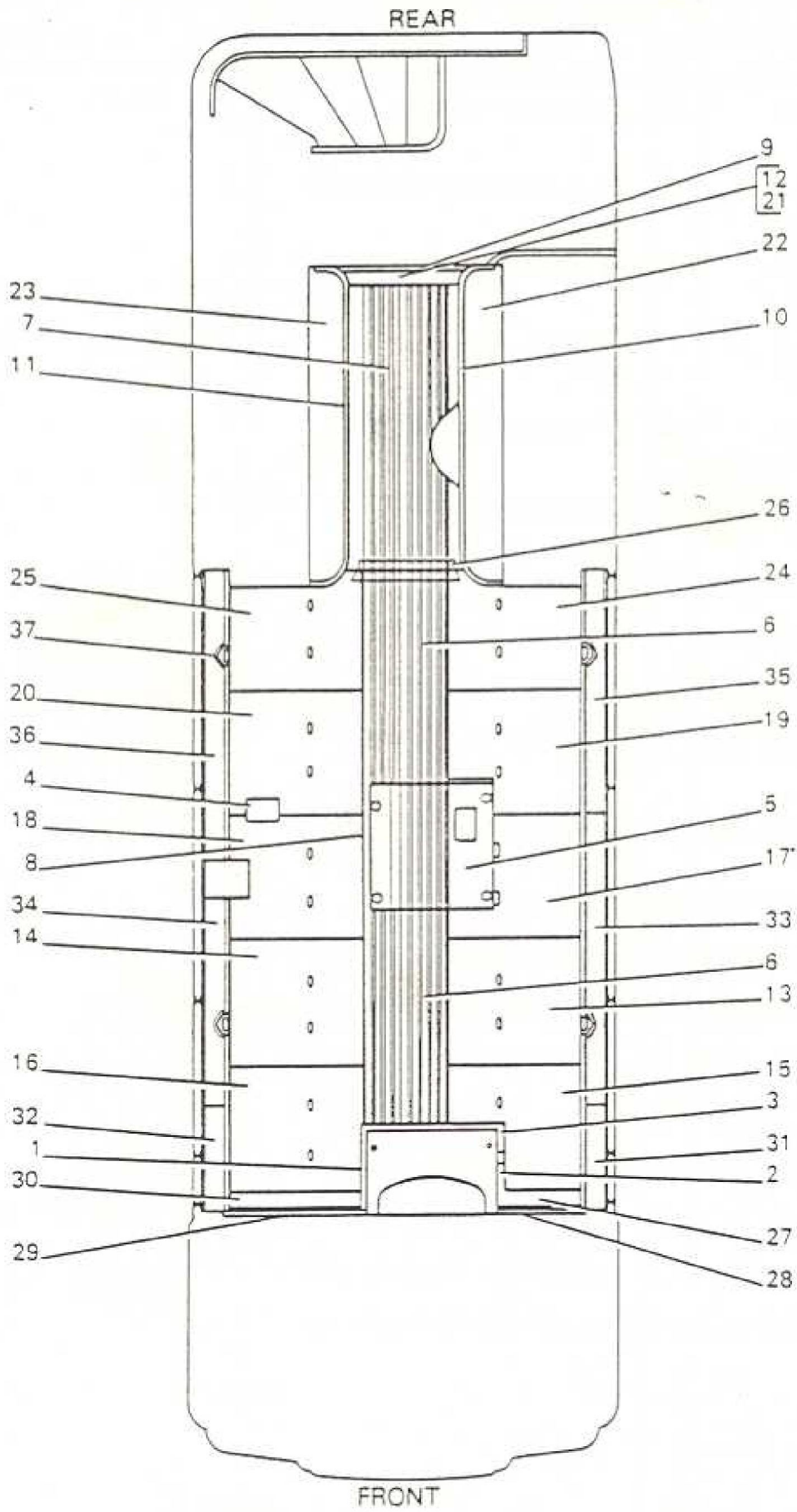

ITEM	MAN. REF.	PART NUMBER	ASSEMBLY - A		DETAIL - D		QTY.	REMARKS	ISSUE
			A/D		DESCRIPTION				
24		RM 027 BL6	D		Floor Tile No. 5 N/S		1		
25		RM 027 BL7	D		Floor Tile No. 5 O/S		1		
*		RM 012 BL59	D		Floor Cover Plate N/S		1		
*		RM 012 BL60	D		Floor Cover Plate O/S		1		
*		RM 012 BL61	D		Floor Slat - Centre No. 4 Bay		2	After BA 480	
26		RM 034 BL1	A		Floor Fixing Plate		1	After ADV BA 491	
27		RM 001 A53	D				1		
28		RM 001 A54	D				1		
29		RM 001 A55T	D				1		
30		RM 001 A56	D				1		
31		RM 001 PL4	D		Front Coving Panel N/S		1		
32		RM 001 PL5	D		Front Coving Panel O/S		1		
33		RM 001 PL6	D		Centre Coving Panel N/S		1		
34		RM 001 PL7	D		Centre Coving Panel O/S		1		
35		RM 001 PL8	D		Rear Coving Panel N/S		1		
36		RM 001 PL9	D		Rear Coving Panel O/S		1		
*		RM 001 PL10	D		Coving Panel Stiffener		3		
37		RM 001 PL29	D		Water Outlet Cover		4		
		<u>RML ONLY</u>							
		ER 012 BL2	D		Slat 2 ft. 4 in. long		4		
		ER 012 BL4	D		Slat 2 ft. 4 in. long		2		
		RM 012 BL12	D		Special Tile		1		
		RM 012 BL13	D		Special Tile		1		
		ER 001 PL9	D		Coving Panel O/S		1		
		ER 001 PL8	D		Coving Panel N/S		1		

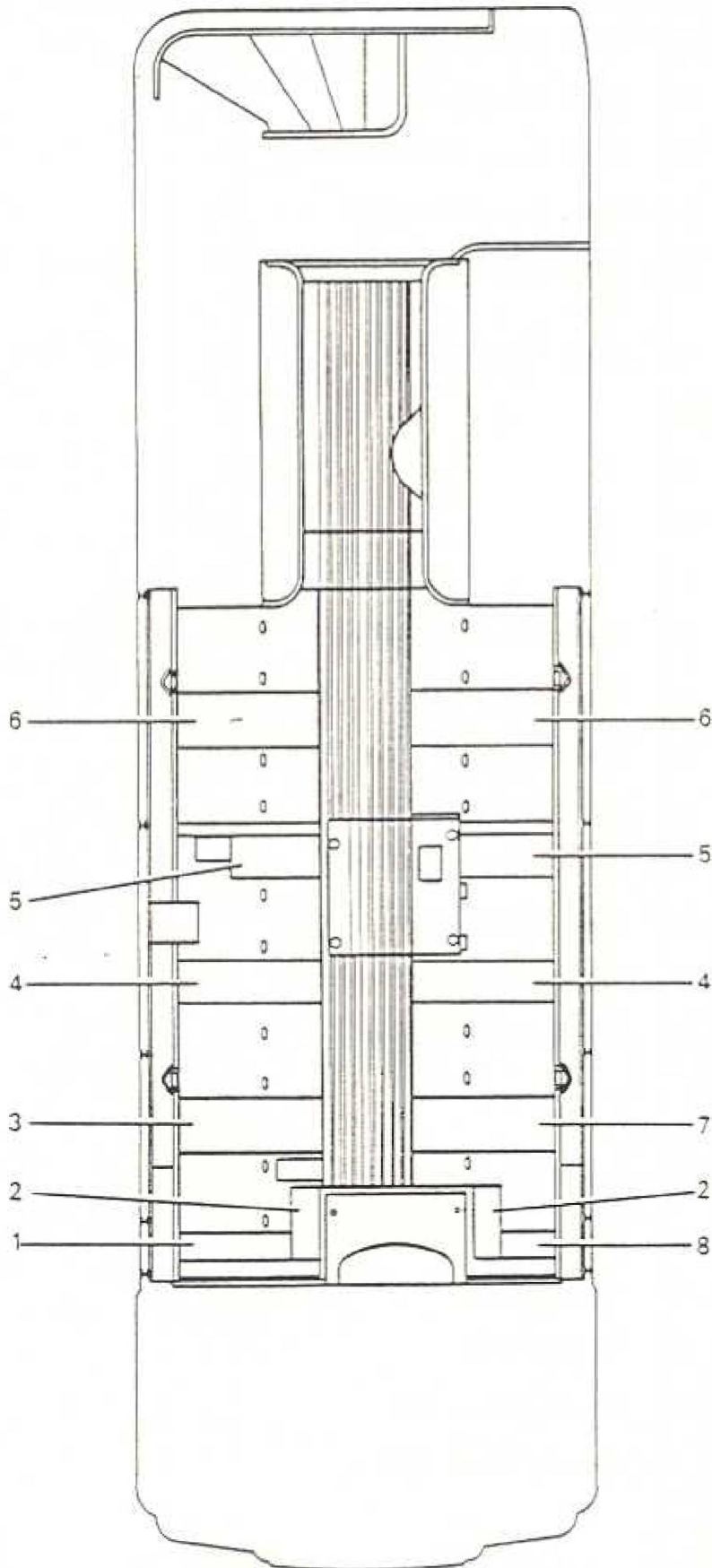

B8L/S FLOOR COVERING
- MULTISLAT -
TREAD PLATES

ITEM	MAN. REF.	PART NUMBER	ASSEMBLY = A		QTY.	REMARKS	ISSUE
			A/D	DETAIL = D			
			DESCRIPTION				
		RM 037 BL	A	Installation of Tread Plates			
1		RM 037 BL3	D	Tread Plate	1		
2		RM 037 BL9	D	Tread Plate	2		
3		RM 037 BL5	D	Tread Plate	1		
4		RM 037 BL6	D	Tread Plate	2		
5		RM 037 BL7	D	Tread Plate	2		
*		RM 037 BL6	D	Tread Plate	4	RM 7 code only	
6		RM 037 BL8	D	Tread Plate	2		
7		RM 037 BL4	D	Tread Plate	1		
8		RM 037 BL2	D	Tread Plate	1		

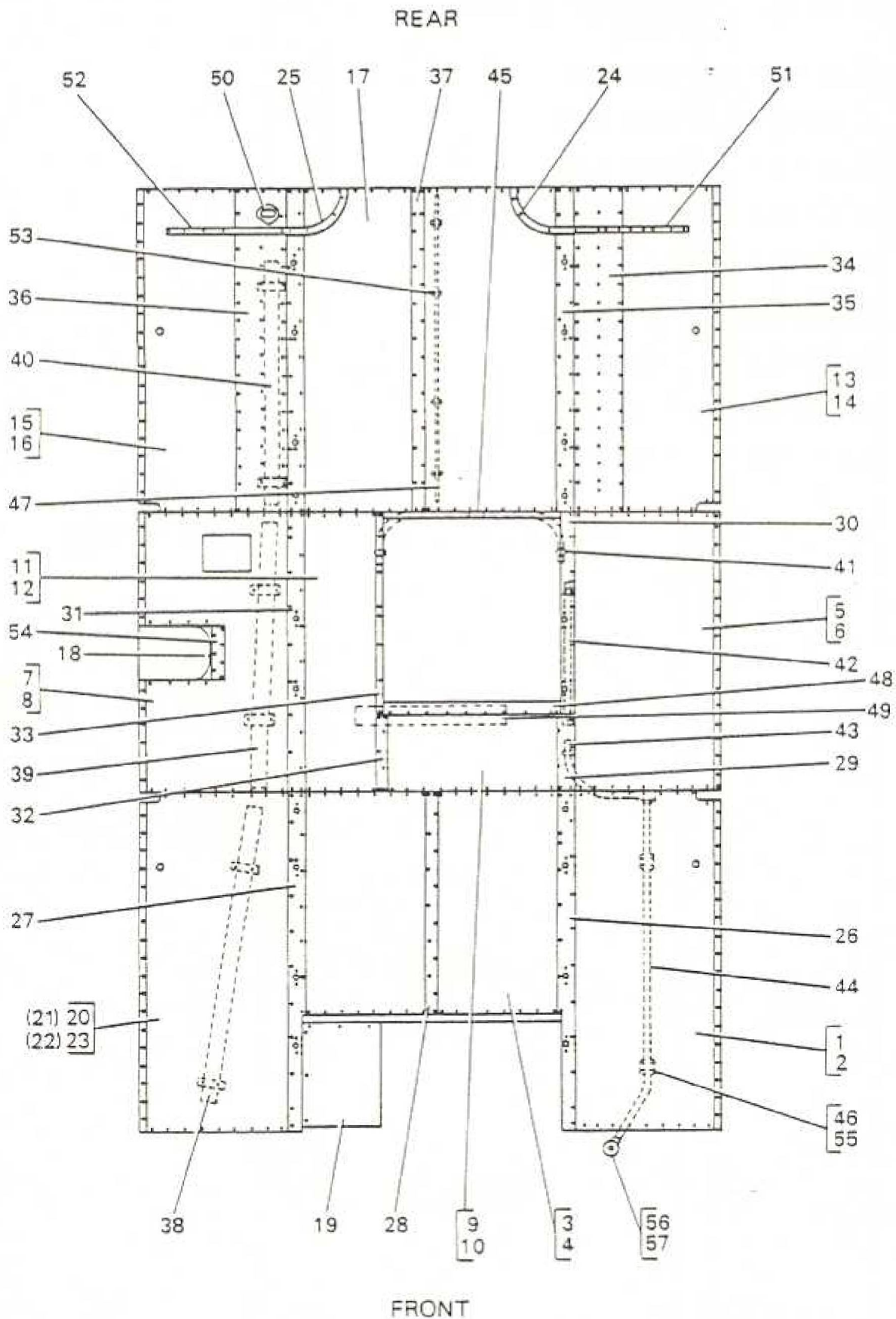

ITEM	MAN. REF.	PART NUMBER	A/D	ASSEMBLY = A	DETAIL = 0	QTY.	REMARKS	ISSUE
				DESCRIPTION				
		RM 001 A1	A	Bottom Frame Comp with Flooring		1		
		RM 002 A1	A	Bottom Frame Structure Front		1	Ref B901 A (D2)	
		RM 003 A1	A	Bottom Frame Structure Rear		1	Ref B901 A (D8)	
1		RM 026 A1	A	Floor No. 1 Bay N/S		1	Before ADV BA 491	
2		RM 142 A1	A	Floor Board No. 1 Bay N/S		1	After ADV BA 491	
3		RM 028 A1	A	Floor No. 1 Bay Centre		1	Before ADV BA 491	
4		RM 135 A1	A	Floor No. 1 Bay Centre		1	After ADV BA 491	
5		RM 029 A1	A	Floor No. 2 Bay N/S		1	Before ADV BA 491	
6		RM 144 A1	A	Floor No. 2 Bay N/S		1	After ADV BA 491	
7		RM 030 A1	A	Floor No. 2 Bay 0/S		1	Before ADV BA 491	
8		RM 143 A1	A	Floor No. 2 Bay 0/S		1	After ADV BA 491	
9		RM 031 A1	A	Floor No. 2 Bay Centre N/S		1	Before ADV BA 491	
10		RM 137 A1	A	Floor No. 2 Bay Centre N/S		1	After ADV BA 491	
11		RM 032 A1	A	Floor No. 2 Bay Centre 0/S		1	Before ADV BA 491	
12		RM 136 A1	A	Floor No. 2 Bay Centre 0/S		1	After ADV BA 491	
13		RM 033 A1	A	Floor No. 3 Bay N/S		1	Before ADV BA 491	
14		RM 146 A1	A	Floor No. 3 Bay N/S		1	After ADV BA 491	
15		RM 034 A1	A	Floor No. 3 Bay 0/S		1	Before ADV BA 491	
16		RM 145 A1	A	Floor No. 3 Bay 0/S		1	After ADV BA 491	
17		RM 035 A1	A	Floor No. 3 Bay Centre		1	Before ADV BA 491	
18		RM 077 A1/F/M	A	Fuel Filler Cowl		1		
19		RM 078 A1	A	Fixed Floor Plate		1		
20		RM 084 A1	A	Floor No. 1 Bay 0/S & Bkt		1	Before ADV SA 491	
21		RM 027 A1	A	Floor No. 1 Bay 0/S		1	Before ADV BA 491	
22		RM 082 A1	A	Clamp Plate & Terminal Block		1	Before ADV BA 491	

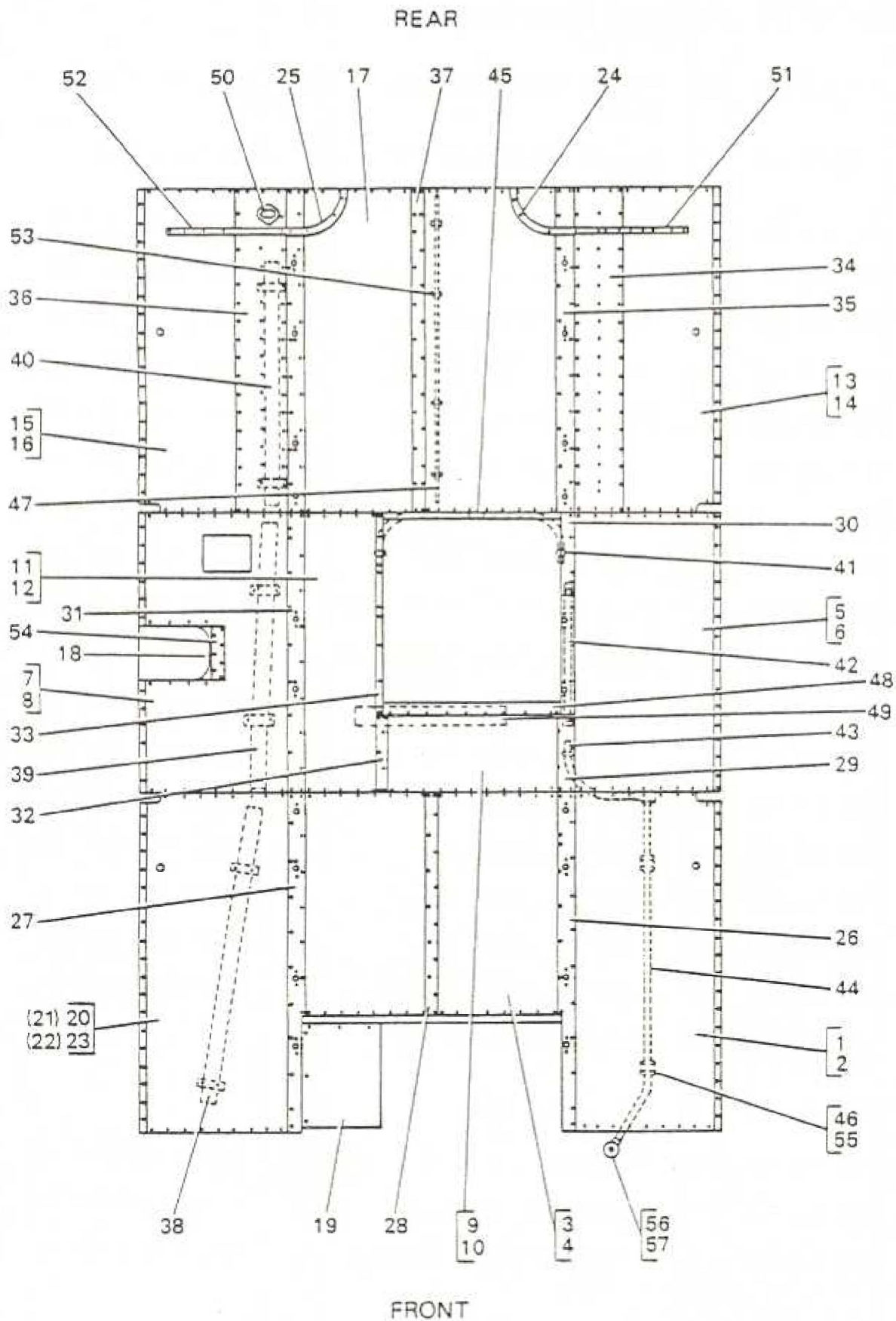

ITEM	MAN. REF.	PART NUMBER	A/D	ASSEMBLY - A	DETAIL - D	QTY.	REMARKS	ISSUE
				DESCRIPTION				
23		RM 138 A1	A	Floor No. 1 Bay 0/S		1	After ADV BA 491	
24		RM 091 A1	A	Footstool End Framing N/S		1		
25		RM 092 A1	A	Footstool End Framing 0/S		1		
26		RM 001 A9	D	Floor Cover Strip - No. 1 Bay N/S		1		
27		RM 001 A10	D	Floor Cover Strip - No. 1 Bay 0/S		1		
28		RM 001 A11	D	Floor Cover Strip - No. 1 Bay Centre		1		
29		RM 001 A12	D	Floor Cover Strip - No. 2 Bay N/S Front		1		
30		RM 001 A13	D	Floor Cover Strip - No. 2 Bay N/S Rear		1		
31		RM 001 A14	D	Floor Cover Strip - No. 2 Bay 0/S		1		
32		RM 001 A15	D	Floor Cover Strip - No. 2 Bay Centre 0/S Front		1		
33		RM 001 A16	D	Floor Cover Strip - No. 2 Bay Centre 0/S Rear		1		
34		RM 001 A18	D	Floor Cover Plate - No. 3 Bay N/S		1		
35		RM 001 A19	D	Floor Cover Strip - No. 3 Bay N/S & 0/S		2	After MOD 145	
36		RM 001 A20	D	Floor Cover Plate - No. 3 Bay 0/S		1		
37		RM 001 A22	D	Floor Cover Strip - No. 3 Bay Centre		1		
38		RM 001 A26	D	PVC Conduit No. 1 Bay		1		
39		RM 001 A27	D	PVC Conduit No. 2 Bay		1		

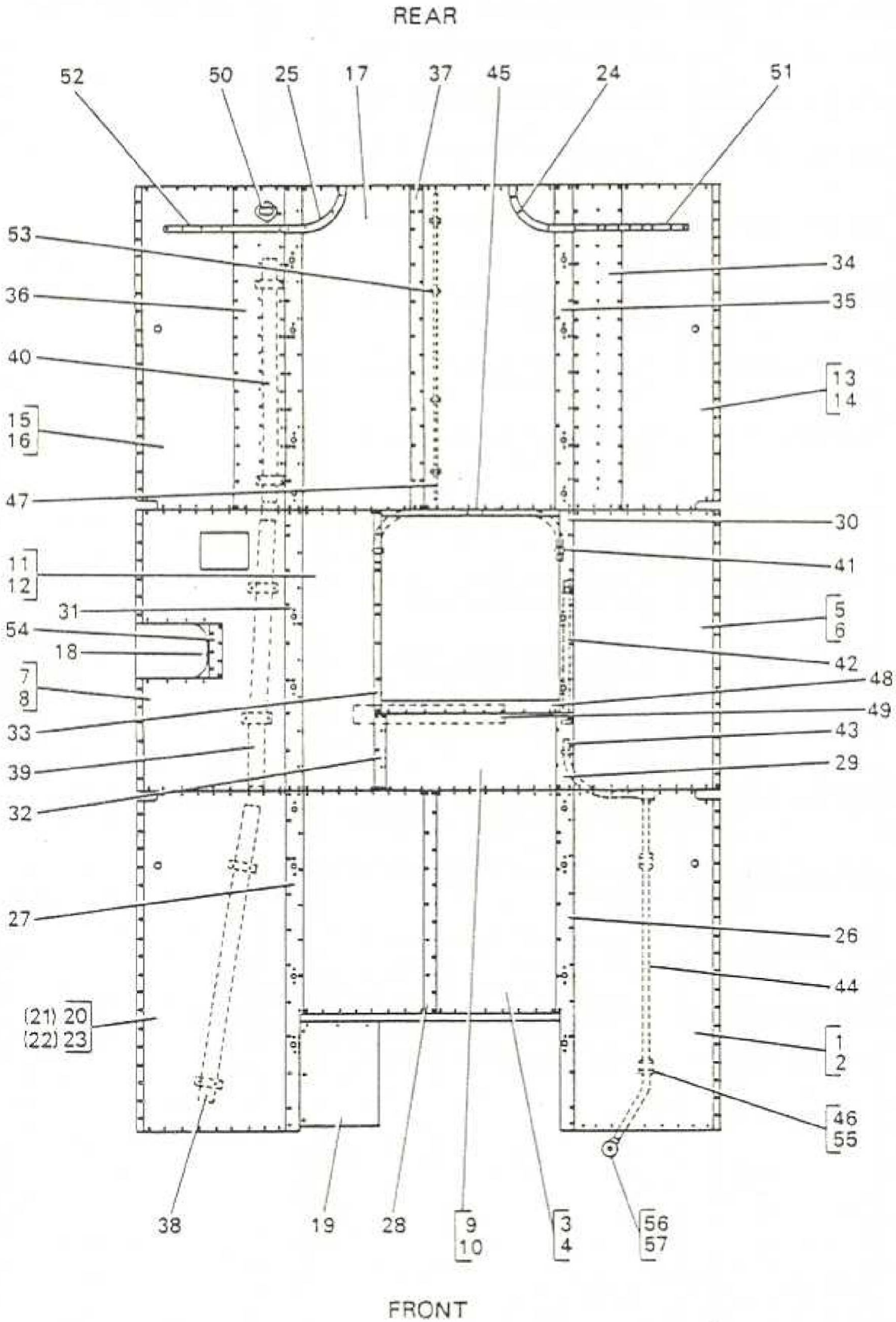

C6L/S BOTTOM FRAME
COMPLETE WITH FLOORINGFICHE NO.
B901A

ITEM	MAN. REF.	PART NUMBER	A/D	ASSEMBLY * A	DETAIL * D	QTY.	REMARKS	ISSUE
				DESCRIPTION				
40		RM 001 A28	D		PVC Conduit No. 3 Bay	1		
41		RM 001 A33	D		Crosswise Conduit No. 3 Cross Bar	1		
42		RM 001 A34	D		Conduit N/S Long'l Rail No. 2 Bay	1		
43		RM 001 A35	D		Conduit No. 2 Cross Bar No. 2 Bay	1		
44		RM 001 A36	D		Conduit No. 1 Bay N/S	1		
45		RM 001 A37	D		Clip - Crosswise Conduit No. 3 Cross Bar	1		
46		RM 001 A38	D		Bracket - Conduit Saddle No. 1 Bay N/S	2		
47		RM 001 A39	D		Conduit No. 3 Bay	1	Before ADV BA 447	
		RM 001 A40	D		Conduit No. 4 Bay	1		
48		RM 001 A41	D		L/S Floor Cover Strip - No. 2 Bay Centre N/S	1	Before BA 491	
49		RM 001 A42	D		Balata Strip - No. 2 Bay	1		
50		RM 040 A6	D		Cable Bush	2	Made from RM 040 A5	
51		RM 001 P9	D		Floor Angle Front Finisher - Long'l Seat N/S	1		
52		RM 001 P10	D		Floor Angle Front Finisher - Long'l Seat O/S	1		
53		RM 001 P52	D		Conduit Saddle 1/2 in. 1/d	7		
54		RM 001 PL11	D		Floor Cover Strip No. 2 Bay O/S (Fuel Cowl)	1	Before ADV BA 447	
55	GEC	CA 6815			Conduit Saddle	8		
56	BFC	41			Junction Box Lid	2		
57	BFC	300 B			Junction Box	2		

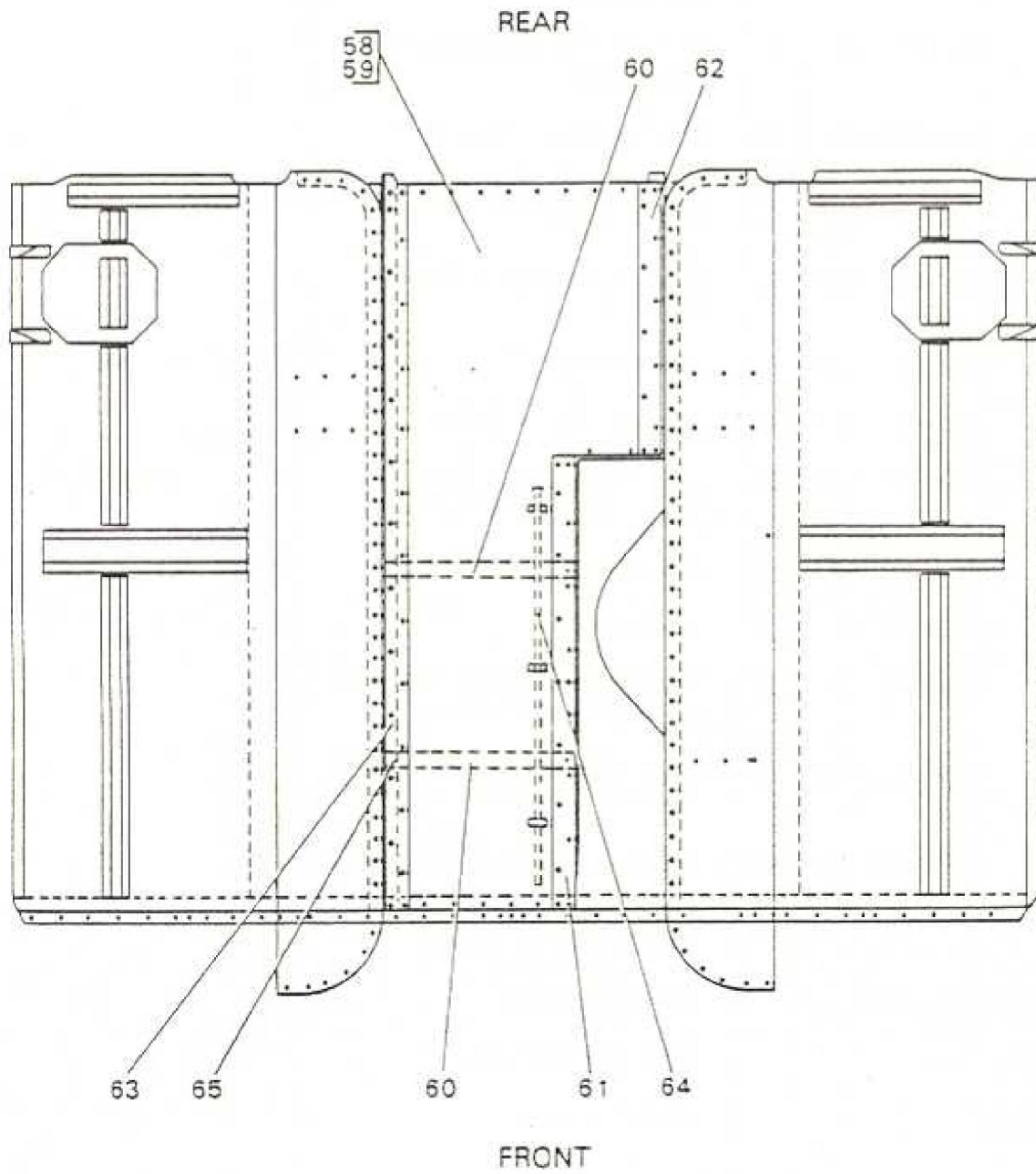

ITEM	MAN. REF.	PART NUMBER	A/D	ASSEMBLY - A	DETAIL - D	QTY.	REMARKS	ISSUE
				DESCRIPTION				
58		RM 036A1	A	Floor No. 4 Bay		1	Before ADV BA 491	
59		RM 133 A1	A	Floor No. 4 Bay		1	After ADV BA 491	
60		RM 001 A43	D	Reinforcing Angle		2	After ADV BA 447	
61		RM 001 A23	D	Floor Covering Strip No. 4 Bay		1		
62		RM 001 A24	D	Floor Covering Strip No. 4 Bay		1	Before ADV BA 491	
63		RM 001 A25	D	Floor Covering Strip No. 4 Bay		1		
64		RM 001 A40	D	Conduit No. 4 Bay		1	Before BA 491	
65		RM 001 A52	D	Bolt Retaining Channel		12		

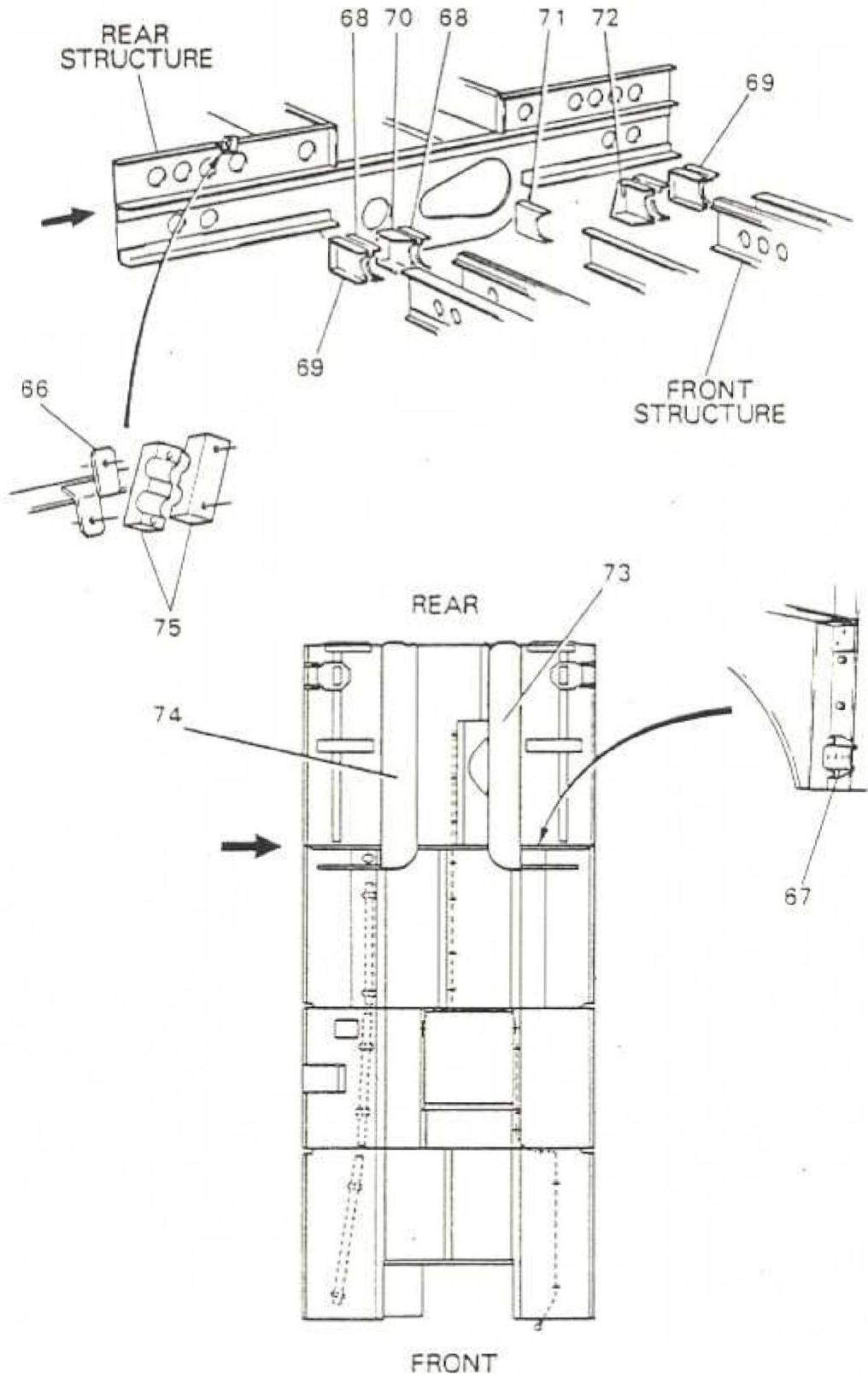

ITEM	MAN. REF.	PART NUMBER	A/D	ASSEMBLY * A	DETAIL * D	QTY.	REMARKS	ISSUE
				DESCRIPTION				
66		RM 089 A1	A	Cable Cleat Bkt No. 4 Bay		1		
67		RM 097 A1	A	Fixed Bkt N/S & O/S		2		
68		RM 001 A2	D	Rear Bkt - Inner Long'l Rail No. 3 Bay		3		
69		RM 001 A3	D	Rear Bkt - Outer Long'l Rail No. 3 Bay		2		
70		RM 001 A4	D	Rear Bkt - Seat Long'l Rail No. 3 Bay		2		
71		RM 001 A5	D	Bkt - Centre Long'l Rail No. 2 & 3 Bay		1		
72		RM 001 A6	D	Rear Bkt - Seat Long'l Rail N/S No. 3 Bay		1		
73		RM 001 A7/F	D	Footstool - Top Plate N/S		1		
74		RM 001 A8/F	D	Footstool - Top Plate O/S		1		
75		RM 002 E31	D	Cable Cleat - Thin		2		

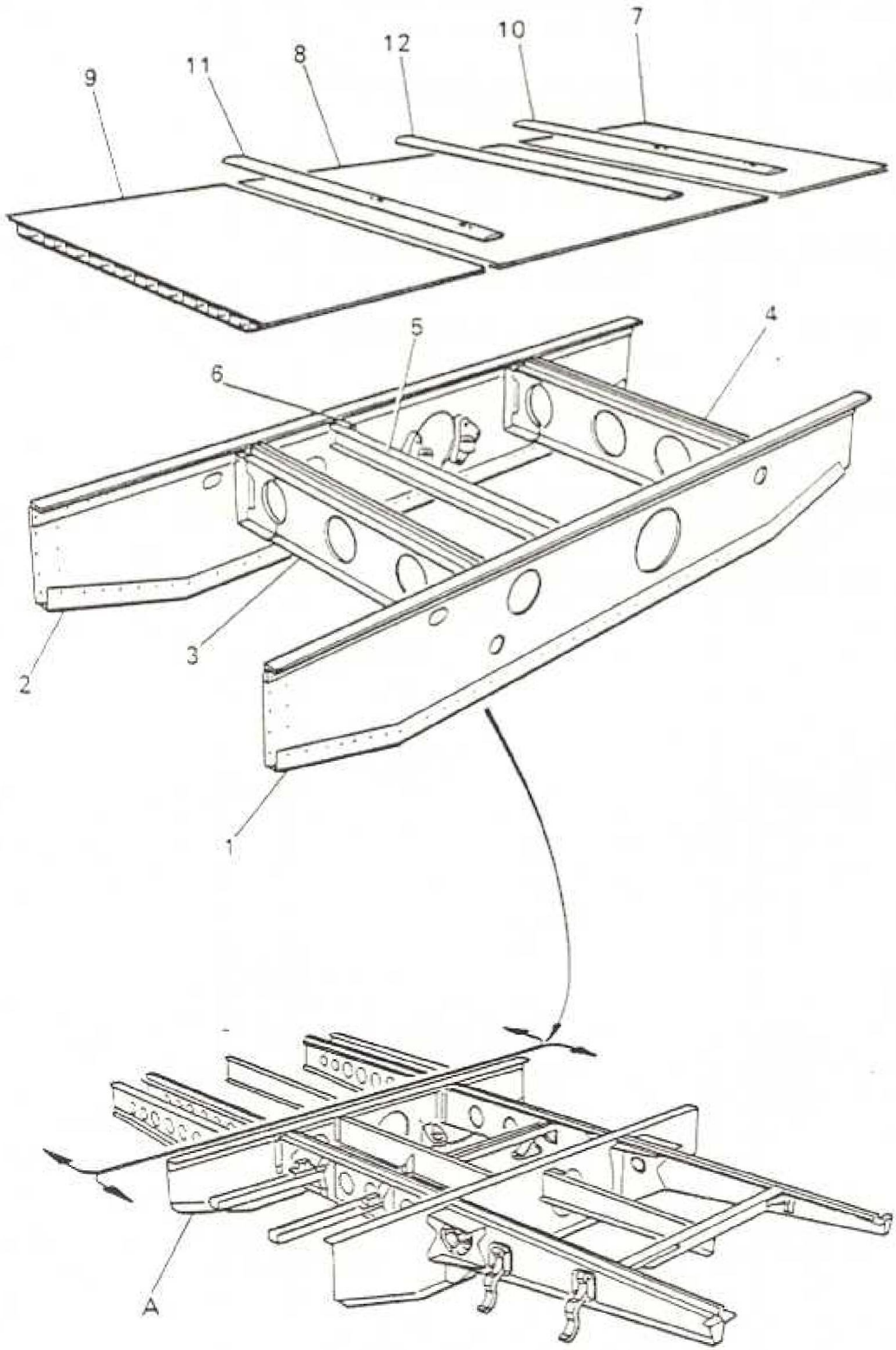

ITEM	MAN. REF.	PART NUMBER	ASSEMBLY - A		QTY.	REMARKS	ISSUE
			A/D	DETAIL - D			
			DESCRIPTION				
		<u>Note 1</u>	The following items are required in addition to items listed for the RM bus under RM 001 A1.				
		<u>Note 2</u>	No. 3 Crossbar (A) is modified from the Standard Bus No. 3 Crossbar (RM 006 A1).				
		ER 501 A	A	Bottom Frame & Floor Centre Bay	1		
1		ER 502 A1	A	No. 3 Crossbar	1	Note 2	
2		ER 503 A1	A	No. 3A Crossbar	1		
3		ER 504 A1	A	Long'l Rail O/S	1		
*		RM 008 A8	D	Locking Plate	2	Front Conn to No. 3 Crossbar	
*		ER 002 A3	D	Rear Bkt Inner	1	Rear Conn to	
*		ER 002 A5	D	Rear Bkt Outer	1	No. 3A Crossbar	
4		ER 505 A1	A	Long'l Rail N/S	1		
*		RM 008 A8	D	Locking Plate	2	Front Conn to No. 3 Crossbar	
*		ER 002 A2	D	Rear Bkt Inner	1	Rear Conn to	
*		ER 002 A4	D	Rear Bkt Outer	1	No. 3A Crossbar	
5		ER 017 A1	A	Centre Long'l Rail	1		
6		RM 001 A5	D	Bracket	1	Rear Conn to No. 3A Crossbar	
7		ER 033 A1	A	Floor N/S	1		
8		ER 035 A1	A	Floor Centre	1		
9		ER 034 A1	A	Floor O/S	1		
10		ER 001 A19	D	Cover Strip N/S	1		
11		ER 001 A21	D	Cover Strip O/S	1		
12		ER 001 A22	D	Cover Strip Centre	1		

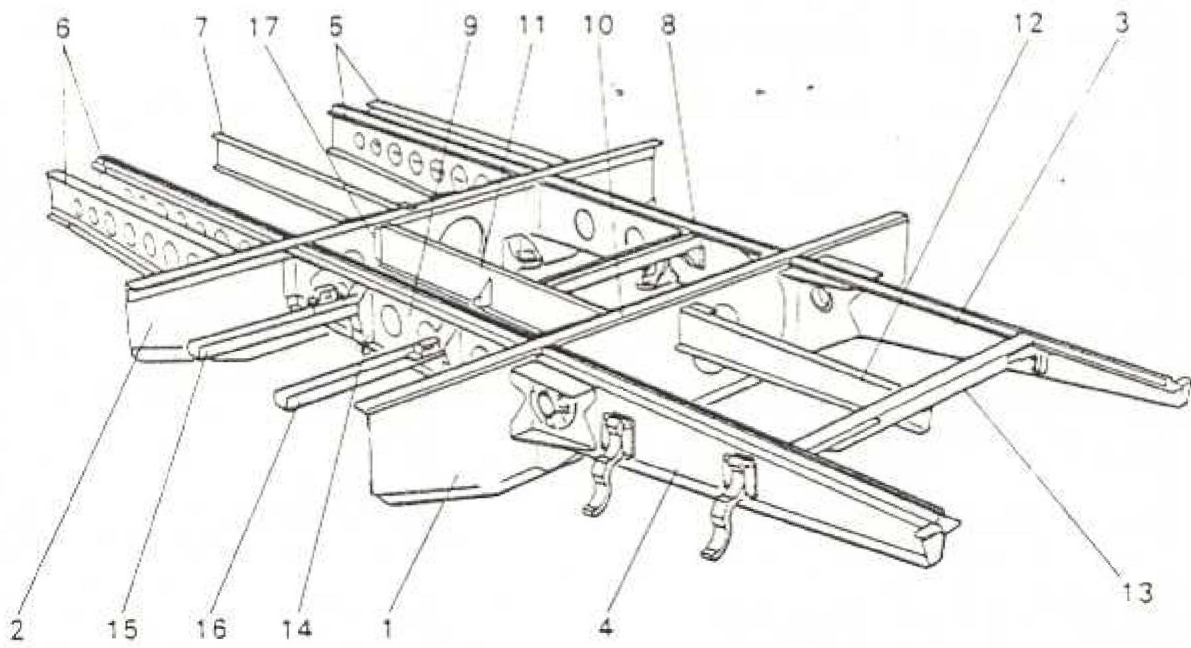

ITEM	MAN. REF.	PART NUMBER	A/D	ASSEMBLY * A	DETAIL * D	QTY.	REMARKS	ISSUE
				DESCRIPTION				
		RM 002 A1	A	Bottom Frame Structure Front		1	Ref RM 001 A1 B901 A (C2)	
1		RM 005 A1	A	No. 2 Crossbar		1		
2		RM 006 A1	A	No. 3 Crossbar		1		
*		RM 014 A1	A	No. 3 Crossbar Sub-Assy		1		
*		RM 037 A1	A	Gearbox Stiffener Bkt N/S		1		
*		RM 038 A1	A	Gearbox Stiffener Bkt O/S		1		
*		RM 065 A1	A	Fixed Support Rail		1		
*		RM 096 A1	A	Detachable Support Rail		1		
3		RM 012 A1	A	Long'l Rail No. 1 Bay N/S		1		
*		RM 018 A1	A	Long'l Rail Sub-Assy		1		
4		RM 013 A1	A	Long'l Rail No. 1 Bay O/S		1		
*		RM 019 A1	A	Long'l Rail No. 1 Bay O/S		1		
5		RM 015 A1	A	Long'l Side Rail No. 3 Bay N/S		1		
*		RM U08 A1	A	Long'l Side Rail Sub- Assy Outer		1		
*		RM 010 A1	A	Long'l Side Rail Sub- Assy Inner		1		
6		RM 016 A1	A	Long'l Side Rail No. 3 Bay O/S		1		
*		RM 009 A1	A	Long'l Side Rail Outer		1		
*		RM 011 A1	A	Long'l Side Rail Inner		1		
*		RM 080 A1	A	Bottom Rail Inner		1		
*		RM 081 A1	A	Conduit Bkt Top Half		2		
7		RM 017 A1	A	Centre Long'l Rail No. 3 Bay		1		
8		RM 020 A1	A	Long'l Rail No. 2 Bay N/S		1		

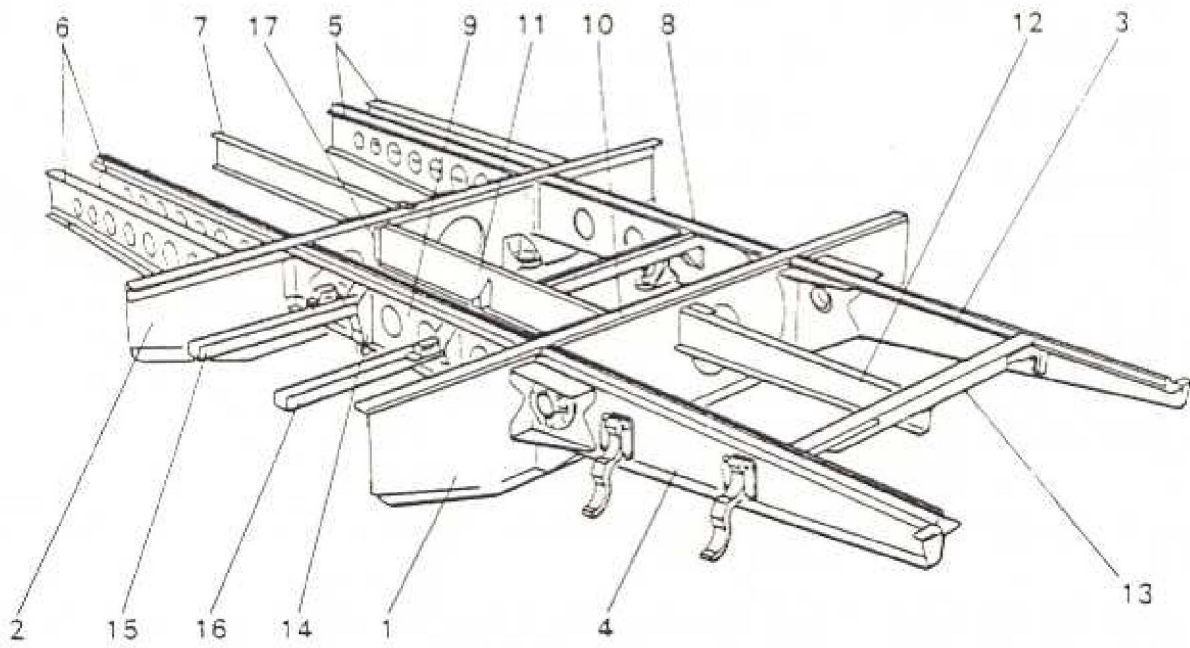

D4L/S BOTTOM FRAME
STRUCTURE FRONT

ITEM	MAN. REF.	PART NUMBER	A/D	ASSEMBLY * A	DETAIL * D	QTY.	REMARKS	ISSUE
				DESCRIPTION				
9		RM 021 A1	A	Long'l Rail No. 2 Bay 0/5		1		
10		RM 023 A1	A	Gearbox Trap Rail No. 2 Bay		1		
11		RM 024 A1	A	Centre Long'l Rail No. 2 Bay		1		
12		RM 054 A1	A	Centre Long'l Rail No. 1 Bay		1		
13		RM 056 A1	A	Flywheel Cowl Cross Rail		1		
14		RM 083 A1	A	Fuel Tank Support Front End Channel		1		
15		RM 085 A1	A	Fuel Tank Support Rear End Channel		1		
16		RM 086 A1	A	Fuel Tank Bkt		2		
*		RM 119 A1	A	Brake Rod Steady Bkt.		1		
17		RM 001 A5	D	Bkt Centre Long'l Rail No. 2 Bay		2		

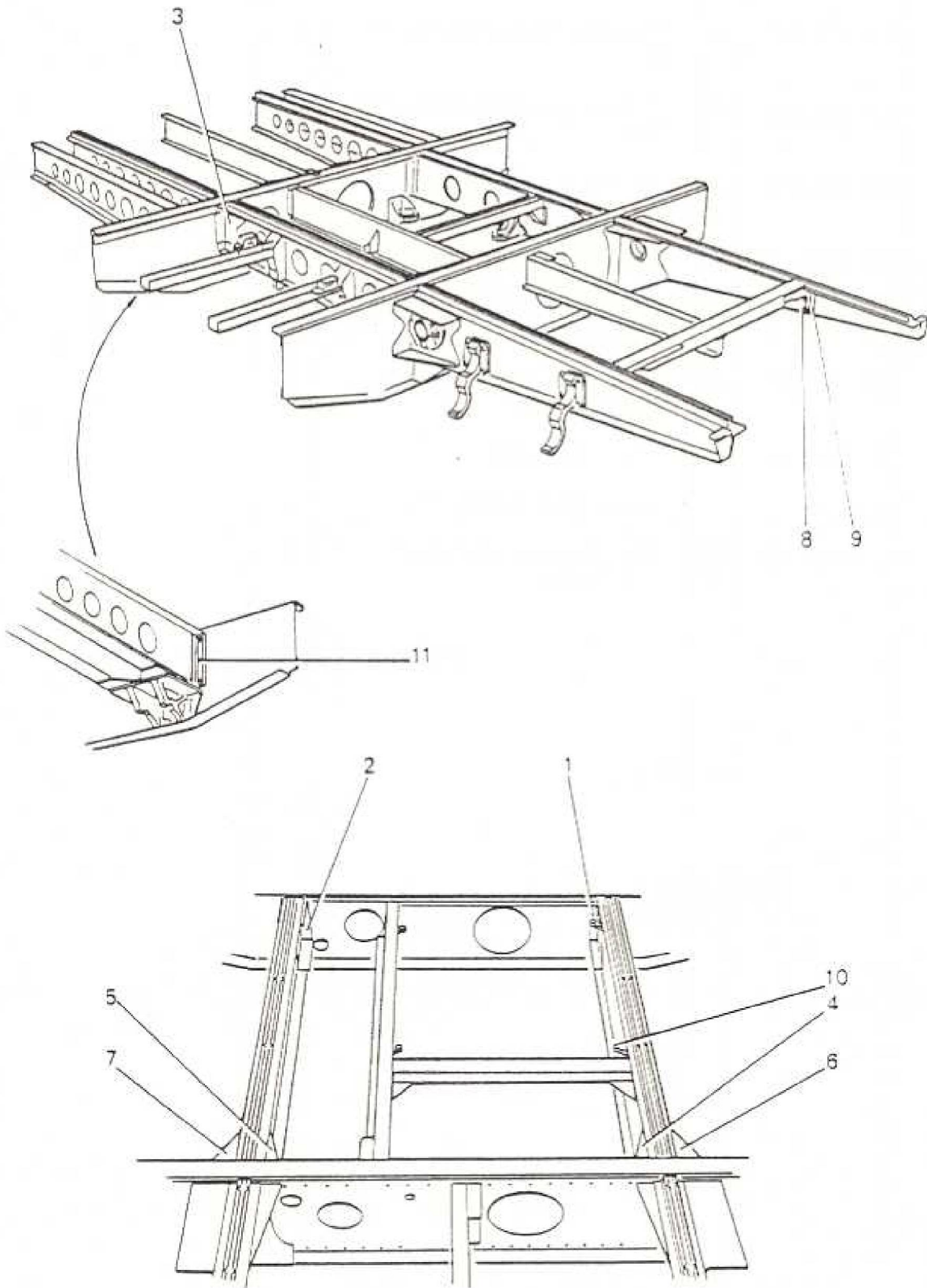

D6L/S BOTTOM FRAME
STRUCTURE FRONTFICHE NO.
B901A

ITEM	MAN. REF.	PART NUMBER	A/D	ASSEMBLY - A	DETAIL - D	QTY.	REMARKS	ISSUE
				DESCRIPTION				
1		RM 002 A2	D	Rear Bkt (Inner) Seat Long'l Rail No. 2 Bay N/S		1		
2		RM 002 A3	D	Rear Bkt (Inner) Seat Long'l Rail No. 2 Bay O/S		1		
*		RM 002 A4	D	Rear Bkt (Outer) Seat Long'l Rail No. 2 Bay N/S		1		
3		RM 002 A5	D	Rear Bkt (Outer) Seat Long'l Rail No. 2 Bay O/S		1		
4		RM 002 A6	D	Front Bkt (Inner) Seat Long'l Rail No. 2 Bay N/S		1		
5		RM 002 A7	D	Front Bkt (Inner) Seat Long'l Rail No. 2 Bay O/S		1		
6		RM 002 A8	D	Front Bkt (Outer) Seat Long'l Rail No. 2 Bay N/S		1		
7		RM 002 A9	D	Front Bkt (Outer) Seat Long'l Rail No. 2 Bay O/S		1		
8		RM 002 A11	D	L/H Support Bkt Cross Rail No. 1 Bay		2		
9		RM 002 A12	D	R/H Support Bkt Cross Rail No. 1 Bay		2		
10		RM 002 A14	D	Gearbox Trap Retaining Bkt		4		
		RM 159 A1	A	Gearbox Trap Retaining Bkt		4	After A/A BZ 1030	
*		RM 002 A16	D	Packing - Inner Bkt No. 2 Bay		-	If required 1 off	
*		RM 002 A17	D	Bkt, Terminal Block		1	After MOD 169	
*		RM 002 A18	D	Packing, Accumulator Bkt		2	RM 5/9 & RM 5/100 only	
11		RM 008 A8	A	Locking Plate		8		

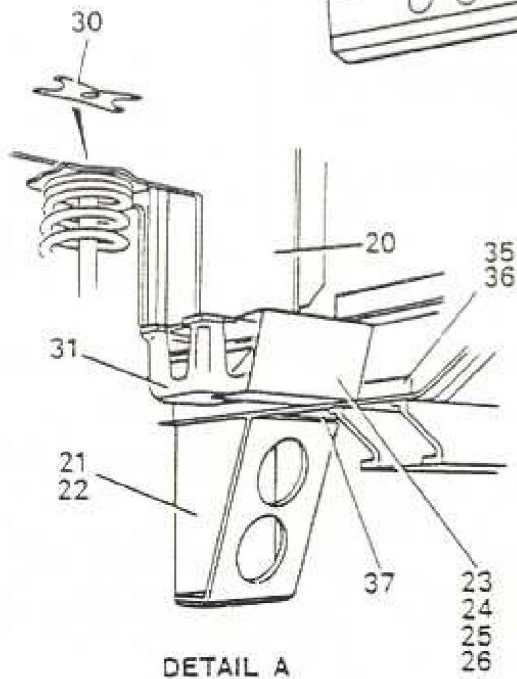
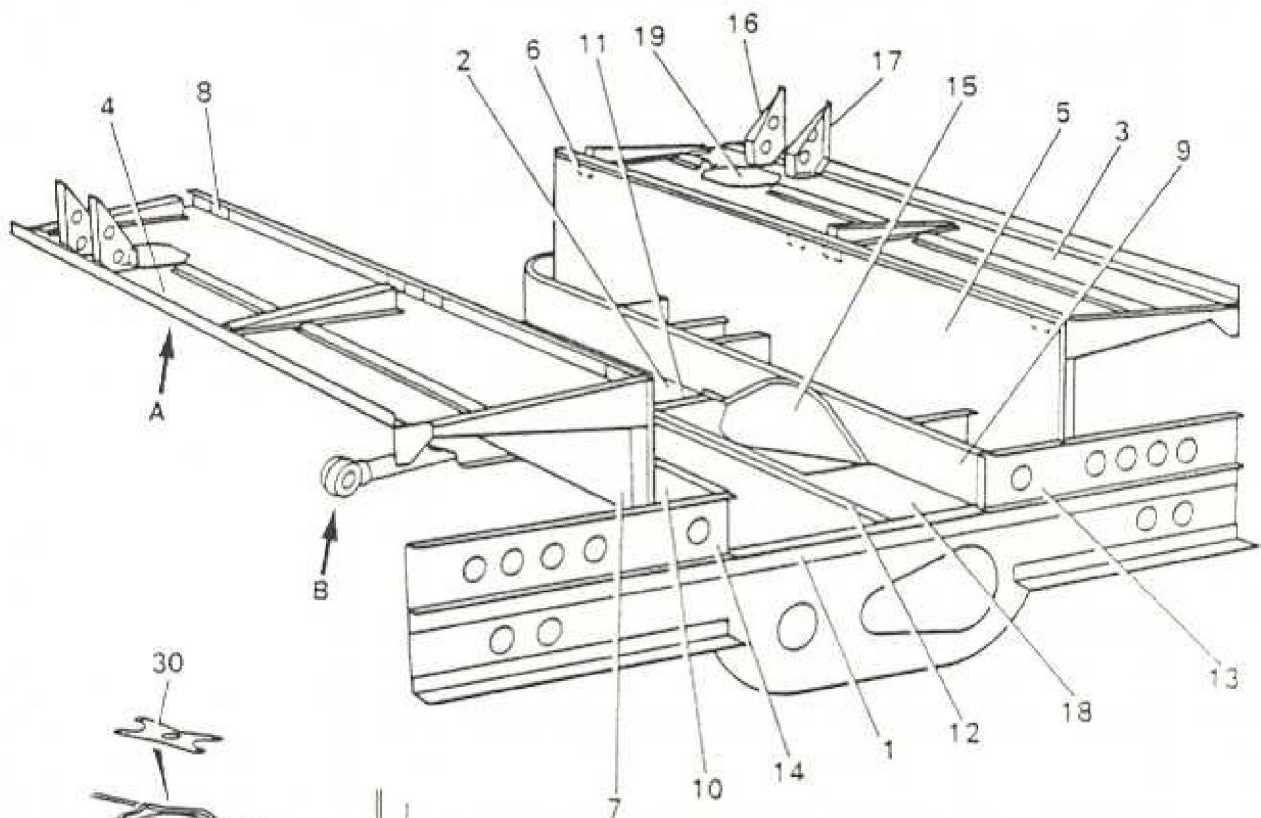

DETAIL A

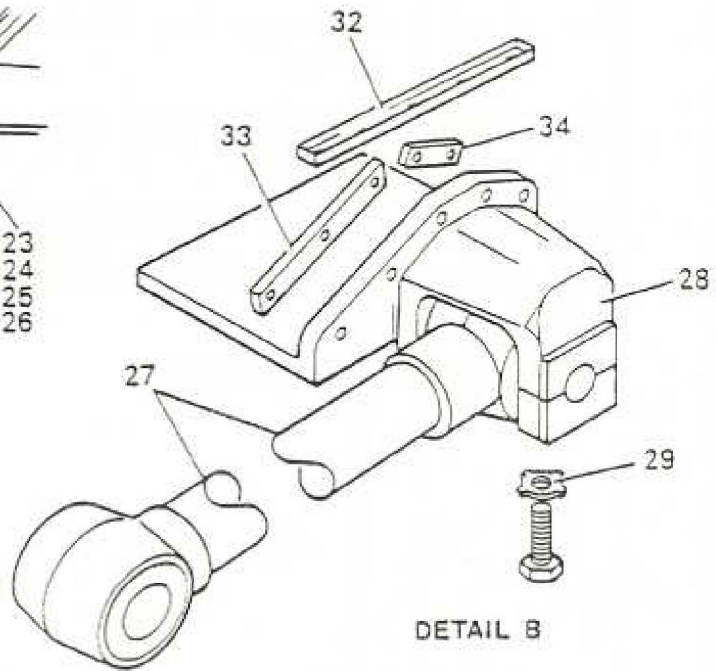

DETAIL B

ITEM	MAN. REF.	PART NUMBER	A/D	ASSEMBLY - A	DETAIL - D	QTY.	REMARKS	ISSUE
				DESCRIPTION				
		RM 003 A1	A	Bottom Frame Structure Rear End		1	Ref RM 001 A1 B901 A (C2)	
1		RM 007 A1	A	No. 4 Crossbar		1		
2		RM 115 A1	A	Panhard Rod Beam		1	After MOD 334	
3		RM 039 A1	A	Wheelarch Beam Top Plate N/S		1		
4		RM 040 A1	A	Wheelarch Beam Top Plate O/S		1		
5		RM 041 A1	A	Wheelarch Beam N/S		1		
6		RM 043 A1	A	Seat Fixing Bkt Long'l Seat		4		
7		RM 042 A1	A	Wheelarch Beam O/S		1		
8		RM 043 A1	A	Seat Fixing Bkt Long'l Seat		4		
9		RM 044 A1	A	Footstool Framing Rear N/S		1		
10		RM 045 A1	A	Footstool Framing Rear O/S		1		
11		RM 150 A1	A	Crosswise Angle N/S		1	After ADV BA 491	
*		RM 048 A1	A	Crosswise Angle N/S		1	Before ADV BA 491	
12		RM 049 A1	A	Long'l Angle N/S		1		
13		RM 052 A1	A	Support Bkt W/Arch Beam No. 4 Pillar N/S		1		
14		RM 053 A1	A	Support Bkt W/Arch Beam No. 4 Pillar N/S		1		
15		RM 073 A1	A	Axle Pot Cowl		1		
16		RM 003 A2	D	Side Frame Stiffener Bkt L/H		2		
17		RM 003 A3	D	Side Frame Stiffener Bkt R/H		2		
18		RM 003 A5	D	Cover Plate		1		
19		RM 003 A8	D	Cover Plate - Rear Springs		2		

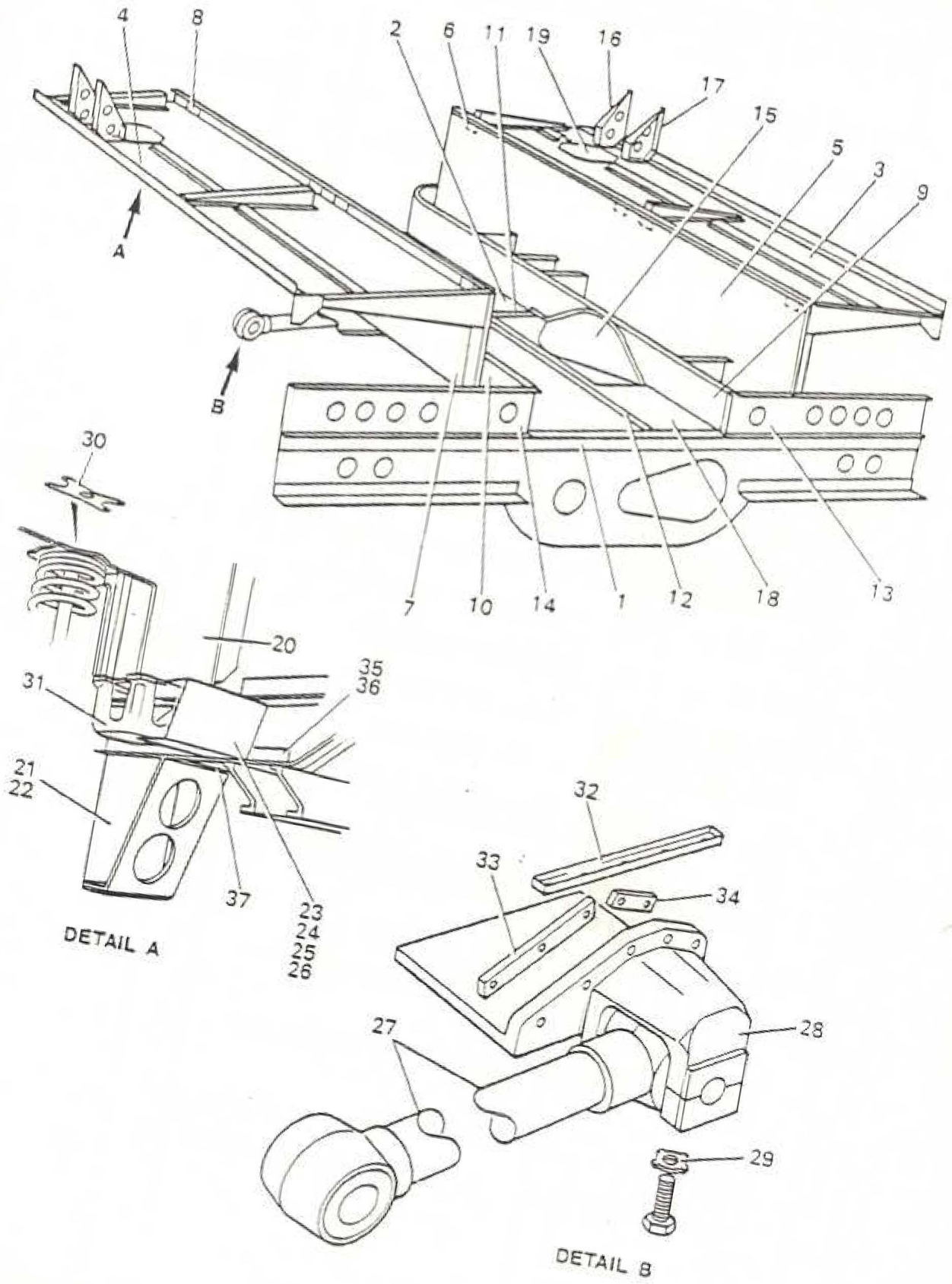

ITEM	MAN. REF.	PART NUMBER	A/D	ASSEMBLY - A	DETAIL - D	QTY.	REMARKS	ISSUE
				DESCRIPTION				
20		RM 025 A1	A	Rear Spring Diaphragm N/S & O/S		2		
21		RM 050 A1	A	Buttress Bkt N/S		1		
22		RM 051 A1	A	Buttress Bkt O/S		1		
23		RM 093 A1	A	Support Bkt W/Arch Rear N/S		1		
24		RM 094 A1	A	Support Bkt W/Arch Panel Rear O/S		1	Before ADV BA 500	
25		RM 140 A1	A	Support Bkt W/Arch Panel Rear N/S		1	After ADV BA 500	
26		RM 141 A1	A	Support Bkt W/Arch Panel Rear O/S		1	After ADV BA 500	
27	AEC	Y1/81U2	A	Panhard Rod		1	Reference only	
28	AEC	FA 1803	A	Support Bkt and Cap		1		
29	AEC	Z8/30674	P	Tabwasher		4	After MOD 334	
30	AEC	Y/30130	D	Top Bkt for Shock Absorber		2	ADV BA 430	
*	AEC	FA/23U2	D	Top Bkt for Rear Spring		2		
31		RM 003 A7	D	Bump Stop Plate		2		
32		RM U03 A9	D	Belt Retaining Channel		1	After MOD 334	
33		RM 003 A10	D	Bolt Retaining Channel		1	ADV BA 430	
34		RM 003 A11	D	Bolt Retaining Channel		1		
35		RM 003 A12	D	Strengthening Angle W/Arch Beam N/S		1	After ADV BA 500	
36		RM 003 A13	D	Strengthening Angle W/Arch Beam O/S		1		
37		RM 003 A14	D	Strengthening Plate - Panhard Beam		1		