

A1

Index

DESCRIPTION	FRAME NO.
REAR FRAME STRUCTURE STAIRCASE FEWDER AND STAIRWELL PANELS	A2 to A7 B1 to B4

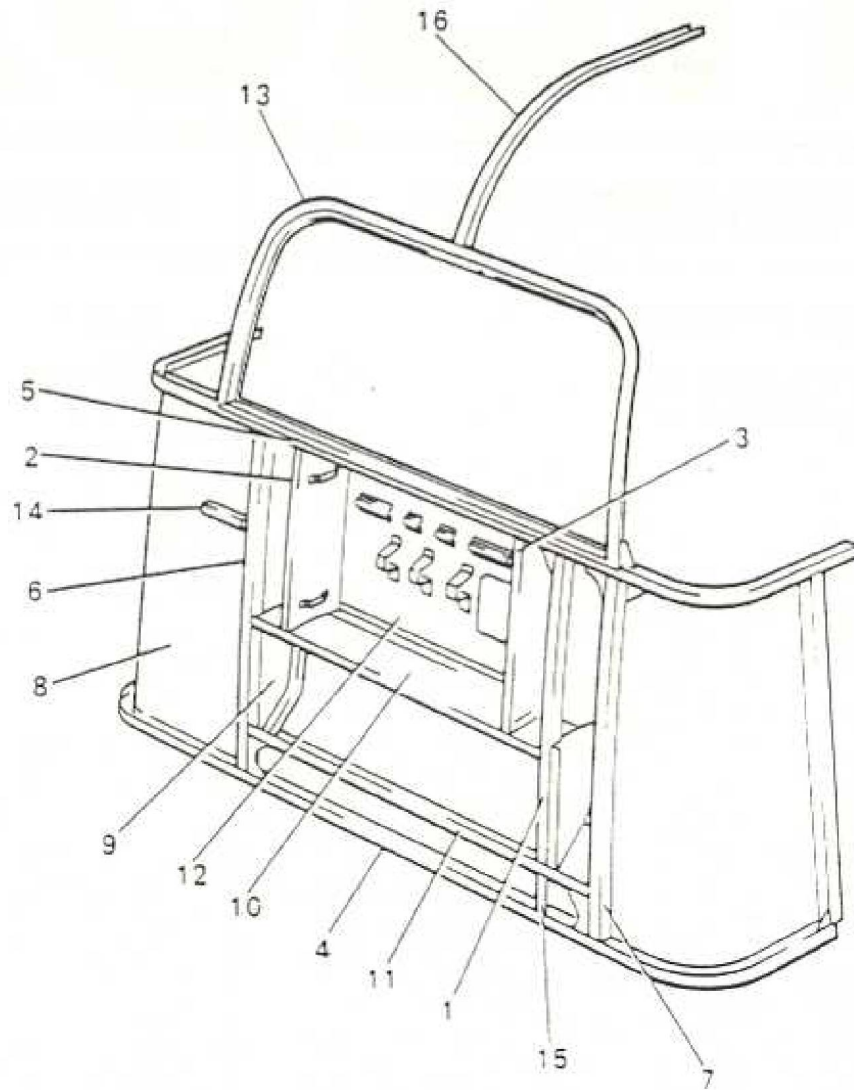

ITEM	MAN. REF.	PART NUMBER	A/D	ASSEMBLY - A	DETAIL - D	QTY.	REMARKS	ISSUE
				DESCRIPTION				
		RM 002 FU1	A	Rear Frame Structure		1	Ref RM 001 FU1 B901 EU (E2)	
1		RM 015 FU1	A	Panel Joint Pillar O/S		1		
2		RM 018 FU1	A	Diaphragm N/S Route Box		1	Not RM 9 Bus	
*		RM 019 FU1	A	Stud Plate Stop Joint		1		
*		RM 020 FU1	A	Saddle Pressure Plate Route Gear		2		
3		RM 021 FU1	A	Diaphragm O/S Route Box		1	Not RM 9 Bus	
*		RM 022 FU1	A	Saddle Route Gear		2		
*		RM 023 FU1	A	Stud Plate Conduit Flap		1		
4		RM 024 FU1	A	Lower Cantrail		1		
5		RM 025 FU1	A	Waist Rail		1		
6		RM 026 FU1	A	Pillar N/S		1		
*		RM 006 FU1	A	Bkt Pillar Bottom Rail		1		
7		RM 027 FU1	A	Pillar O/S		1		
*		RM 007 FU1	A	Bkt Pillar Bottom Rail		1		
8		RM 029 FU1	A	Stress Panel N/S		1		
*		RM 044 FU1	A	Bkt Terminal Block		1		
9		RM 031 FU1	A	Lower Diaphragm N/S		1		
10		RM 033 FU1	A	Horizontal Panel		1		
*		RM 039 FU	A	Stud Plate		1		
11		RM 034 FU1	A	Hinge Rail Destination Box		1		
12		RM 035 FU1	A	Inside Panel Route Box		1	Not RM 9 Bus	
*		RM 036 FU1	A	Gear Access Door		1		
*		RM 037 FU1/F	A	Hinge Gear Access Door		1		
*		22112-816	A	Budget Lock R/H		1		
*		RM 040 FU1	A	Hand Guard		1		
13		RM 050 FU1	A	Emergency Window Frame Structure		1		

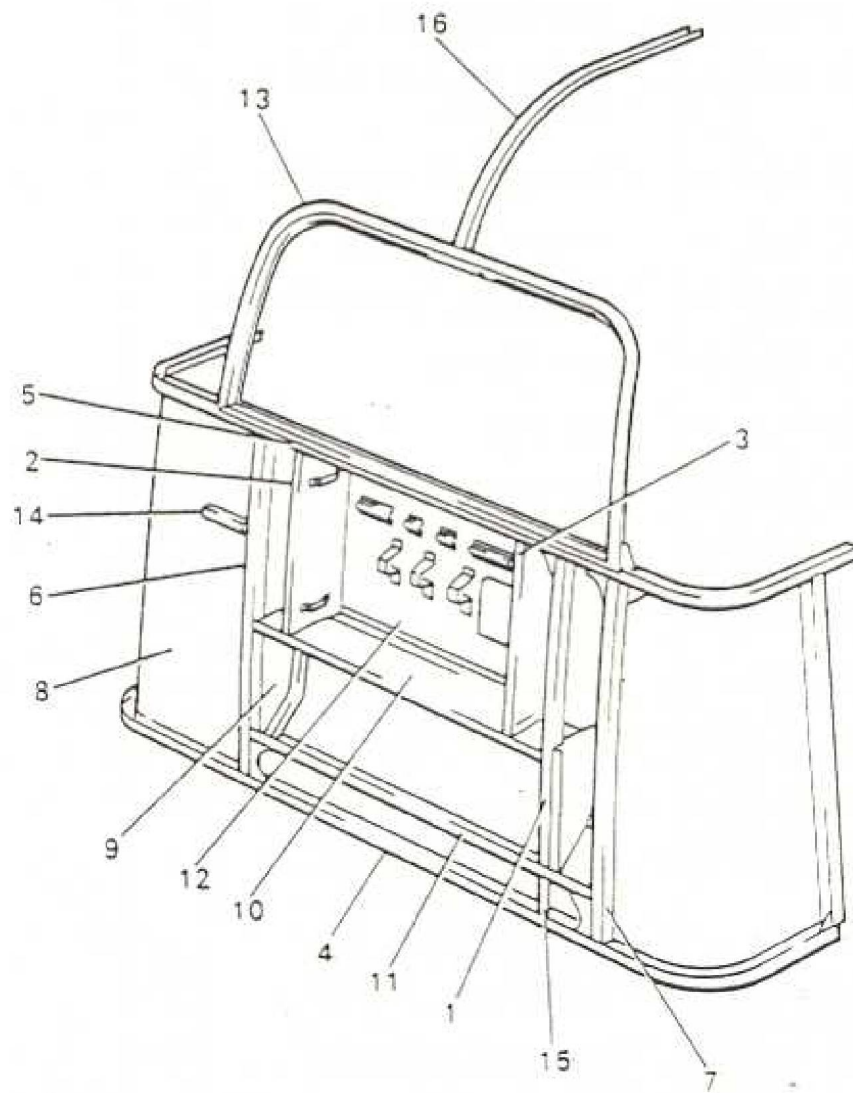

ITEM	MAN. REF.	PART NUMBER	A/D	ASSEMBLY - A	DETAIL - D	QTY.	REMARKS	ISSUE
				DESCRIPTION				
14		RM 064 F1	A	Buffer Block		1		
15		RM 002 FU2	D	Mldg Support Plate		1		
16		RM 002 FU6	D	Centre Conn Rail		1		
*		RM 002 FU8	D	Stress Panel 0/S		1	RM 9 only	
<u>EQUIPMENT FITTED TO RM 9 BUS ONLY</u>								
		RM 080 FU1	A	Diaphragm N/S Route Box		1		
		RM 019 FU1	A	Stud Plate Step Joint		1		
		RM 020 FU1	A	Saddle Pressure Plate Rte Gear		2		
		RM 081 FU1	A	Diaphragm 0/S Route Box		1		
		RM 022 FU1	A	Saddle Route Gear		2		
		RM 023 FU1	A	Stud Plate Conduit Clip		1		
		RM 082 FU1	A	Inside Panel Route Box		1		
		RM 036 FU1	A	Gear Access Door		1		
		RM 040 FU1	A	Hand Guard Rear Route Box		1		
		RM 083 FU1	A	Inside Stress Panel N/S		1		
		RM 044 FU1	A	Bkt Terminal Block		1		
		RM 084 FU1	A	Inner Panel Joint Pillar 0/S		1		

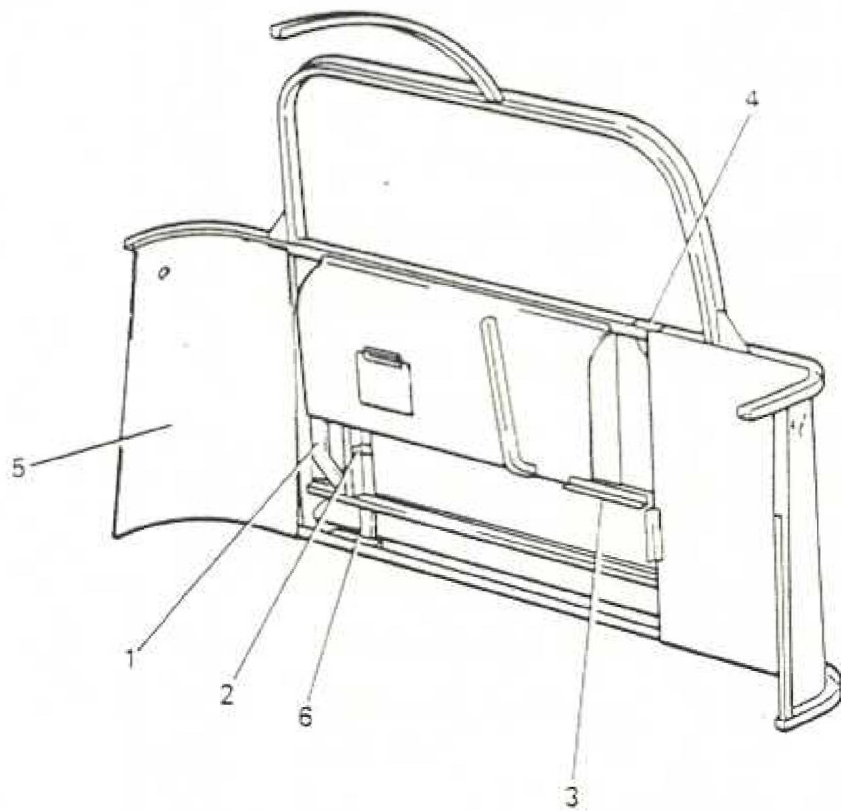

A7U/S REAR FRAME
STRUCTURE

FICHE NO.

B901FU

ITEM	MAN. REF.	PART NUMBER	A/D	ASSEMBLY - A	DETAIL - D	QTY.	REMARKS	ISSUE
				DESCRIPTION				
1		RM 002 FU1	A	Rear Frame Structure		1	Ref RM 001 FU1 B901 EU (A3)	
2		RM 032 FU1	A	Inner Panel Joint Pillar O/S		1	Not RM 9	
3		RM 043 FU1	A	Stud Plate Conduit Fixing		1		
4		RM 002 FU3	D	Fixing Angle Stairwell Panel		1		
5		RM 002 FU4/T	D	Hinge Fixing Block Rear Waist		2		
6		RM 002 FU5	D	Stress Panel O/S		1	Not RM 9	
		RM 002 FU7T	D	Head Rail Fixing Block		1		

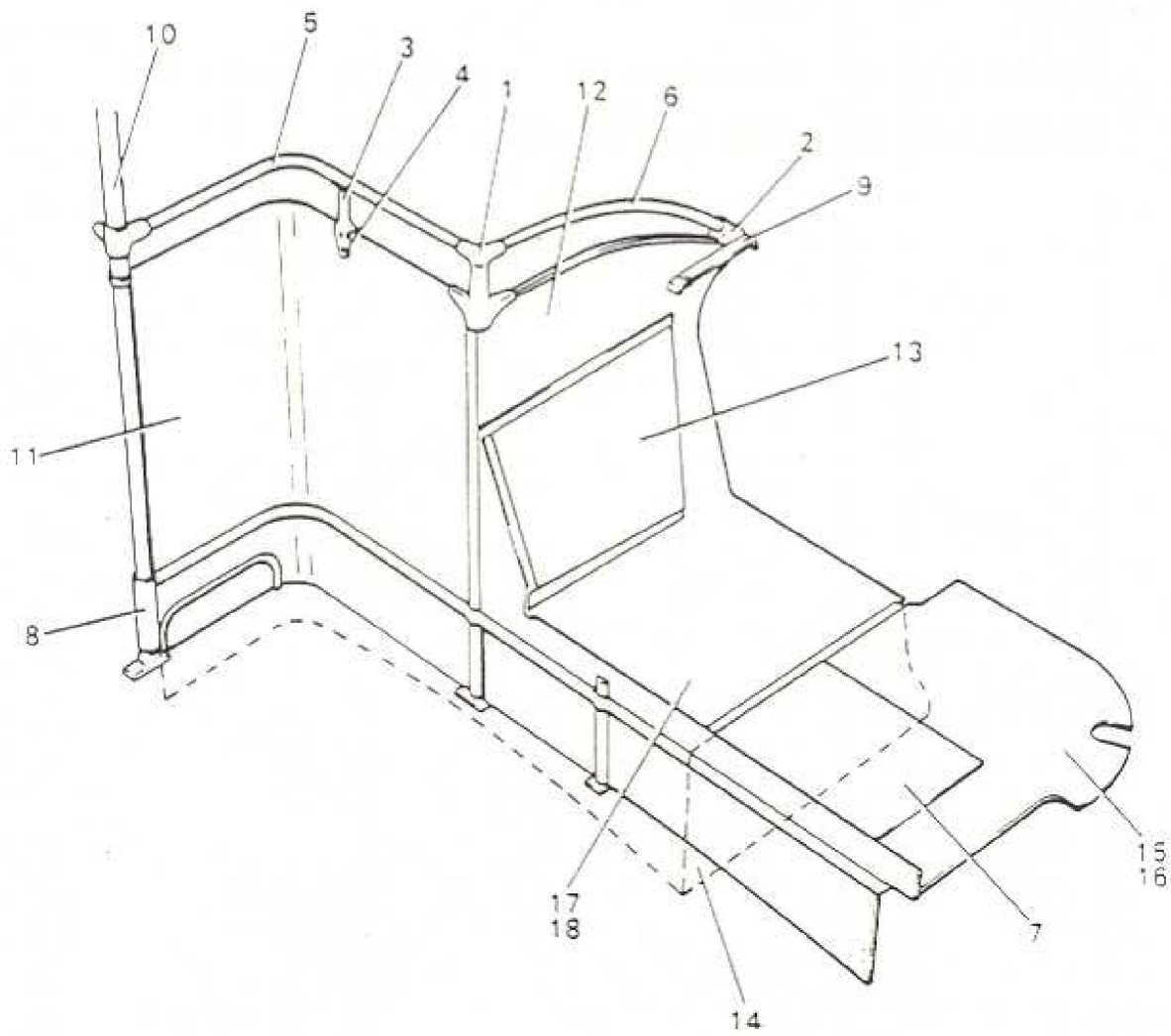

ITEM	MAN. REF.	PART NUMBER	A/D	ASSEMBLY * A	DETAIL * D	QTY	REMARKS	ISSUE
				DESCRIPTION				
		RM 009 K	A	Staircase Fender & Stairwell Panels		Ref		
*		RM 028 K	A	Staircase Fender & Stairwell Panels		1		
1		RM 028 K3	D	Fender Rail Corner Bkt		1		
2		RM 028 K5	D	Fender Rear Rail Bkt		1		
3		RM 028 K7	D	Support Bkt - Fender Rail Front Tube		1		
4		RM 028 K8/F	D	Washer Plate - Staircase Fender		1		
5		RM 028 K9	D	Fender Handrail Tube - Front		1		
6		RM 028 K10	D	Fender Handrail Tube - Rear		1		
7		RM 028 K11	D	Detachable Cover Plate		1		
8		RM 028 K12	D	Kicking Plate Fender Stanchion		1		
*		RM 028 K14/F	D	Fixing Strip - Fender Stanchion		1		
9		RM 028 K16	D	Support Bkt - N/S Rear Squab Top Rail		1		
*		RM 028 K20		Finisher Mldg - Stairwell Panel		1		
10		RM 029 K1	A	Fender Stanchion Tube		1		
11		RM 032 K1	A	Staircase Fender Panel		1		
12		RM 106 K1	A	Stairwell Panel Inner Top		1	After MOD 355	
13		RM 105 K1	A	Stairwell Panel Inner Lower		1	After MOD 355	
14		RM 039 K1	A	Stairwell Panel Outer Bottom		1		
15		RM 041 K1	A	Cover Plate		1	Not on RM 9	
*		RM 040 K1	A	Cover Plate Frame		1		
16		RM 113 K1	A	Cover Plate		1	RM 9 only	

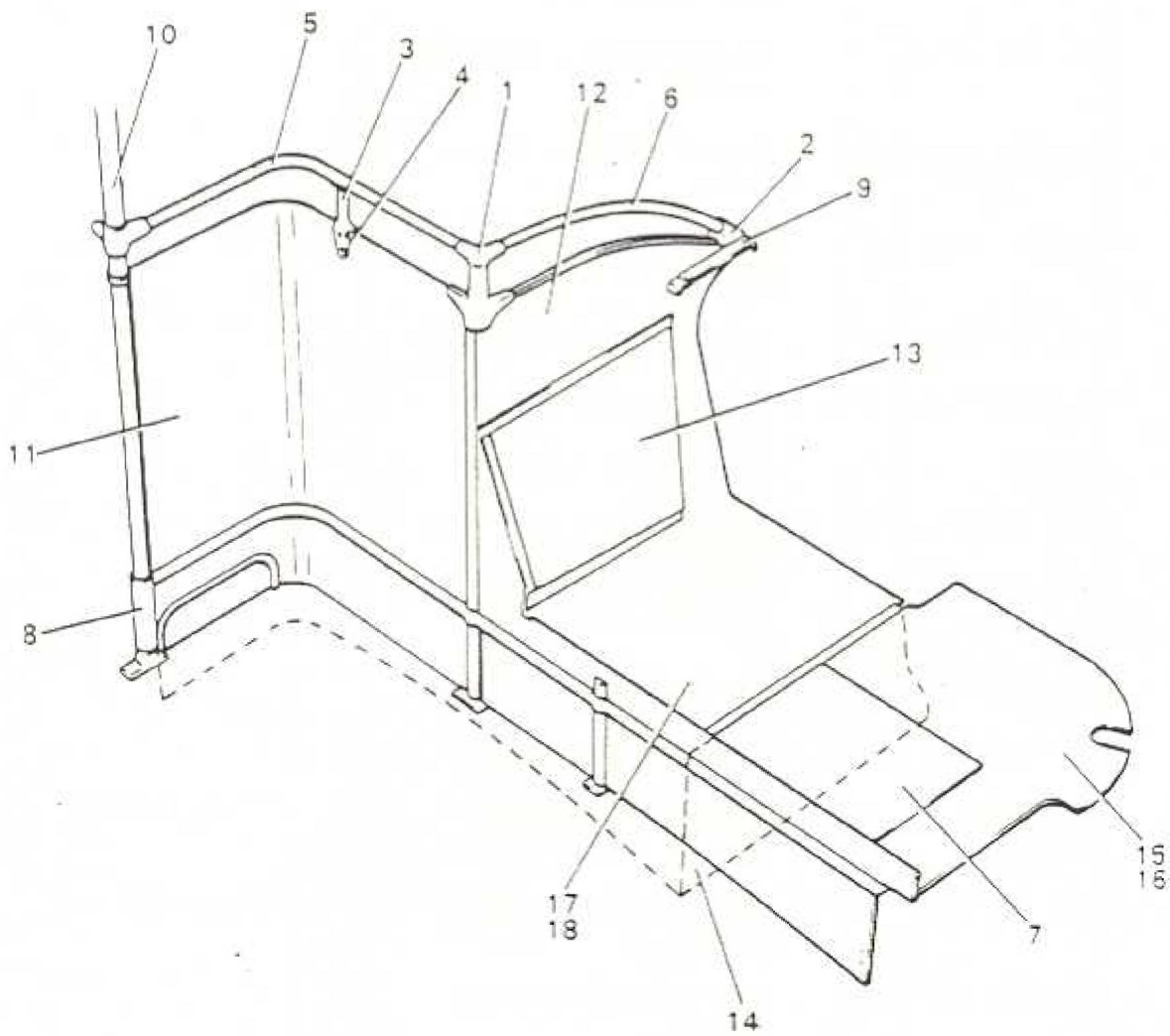

B4U/S STAIRCASE FENDER
& STAIRWELL PANELS

ITEM	MAN. REF.	PART NUMBER	A/D	ASSEMBLY - A	DETAIL - D	QTY.	REMARKS	ISSUE
				DESCRIPTION				
*		RM 040 K1	A		Cover Plate Frame	1		
17		RM 042 K1	A		Stairwell Panel Outer Top	1	Not on RM 9	
18		RM 114 K1	A		Stairwell Panel Outer Top	1	RM 9 only	
*		CR 364 K1	A		Budget Lock Bkt	1	RM 9 only	
*		CR 365 K1	A		Bracket	1	RM 9 only	
*		22112-816	A		Budget Lock	1	RM 9 only	
*		RM 043 K1	A		Finisher Panel Stairwell Panel	1		
*		RM 042 P1	A		Stairwell Finisher Mldg	1		
*		RM 009 K2/F	D		Floor Finisher Plate	1	After MOD 308 ADV BK 192	
*		DM 314 EL1	D		Extinguisher Break Glass	1	GRP	